

Sección 4 Sistemas de soportería para cables

Section 4 Cable tray systems

1. Charola tipo Escalera • *Ladder Type Cable Tray*
2. Charola tipo Fondo Sólido Perforado • *Ventilated Solid Flat Trough Cable Tray*
3. Charola Tipo Fondo Sólido Liso. • *Solid Flat Trough Cable Tray*
4. Conector. • *Splice Plate*
5. Curva Horizontal. • *Horizontal Bend*
6. "T" Horizontal • *Horizontal Tee*
7. Equis Horizontal. • *Horizontal Cross.*
8. Curva Vertical Interior y Exterior • *Outside and Inside Vertical Bend.*
9. "T" Vertical. • *Vertical Tee*
10. Reducción. • *Reducer.*
11. Conector de Charola a Caja. • *Frame Type Box Connector*
12. Barrera Separadora. • *Straight Section Barrier Strip*
13. Tapas (Cubiertas) • *Covers*

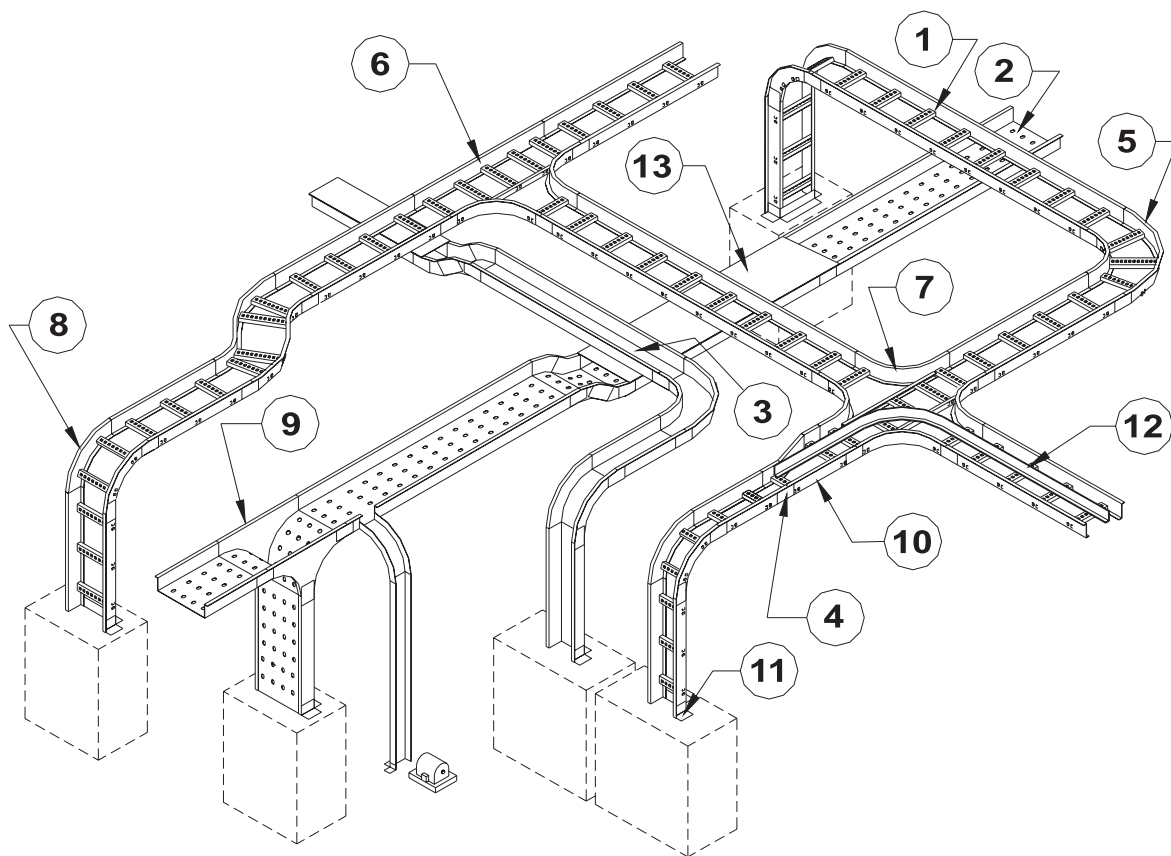

Certificaciones

CERTIFICADO DE CONFORMIDAD DE PRODUCTO

Certificado No. **2000103912**
 Este Certificado número 4 Certificado número: 2000103912
 Página 1 de 2

La Asociación de Normalización y Certificación, A.C., en su carácter de organismo de Certificación de Producto acreditado y aprobado en los términos de la Ley Federal sobre Metrología y Normalización (LFMN), de conformidad con los artículos 1, 2, 3, 4, 5, 6, 7, 8, 9, 10, 11, 12, 13, 14, 15, 16, 17, 18, 19, 20, 21, 22, 23, 24, 25, 26, 27, 28, 29, 30, y demás relativos y aplicables de la misma Ley, así como de su respectivo reglamento, con número de Acreditación 01/10 expedido a partir del 09/03/2010, en atención a la solicitud con número de Referencia **2000103912** de acuerdo al procedimiento de Certificación **PROPARE-01** de ANCE, otorga el presente Certificado de Conformidad de Producto a:

Título: **CORPORACIÓN MANDRINKA, S.A. DE C.V.**

Nombre genérico:	SOPORTE PARA CABLES TIPO CARGOL
Especie:	MILLA
Subtipo:	SIN SUELO
Material:	ACERO LINE
Categoría:	MIXTO
Modalidad:	PROCEDIMIENTO ANCE
Fabricado y/o importado por:	CORPORACIÓN MANDRINKA, S.A. DE C.V.
Dirigido a:	ALEJANDRO VOLTA No. 113 INT. SN COB. PARQUE IND. CUAMATLA DEL. CUAUTITLÁN MICHAEL P. SANCHEZ DE MENDOZA
Fábrica:	ALEJANDRO VOLTA No. 113 INT. SN COB. PARQUE IND. CUAMATLA DEL. CUAUTITLÁN MICHAEL P. SANCHEZ DE MENDOZA
País de origen:	MEXICO
Modelo:	CL-CL, CL (SEGUNDO O NO-CL)
Especificaciones:	Certificación: 08B - Ancho: 400 mm Largo: 3 m Malla: 100 mm x 50 mm Material: Acero Inoxidable

PROCESO 01

CERTIFICADO DE CONFORMIDAD DE PRODUCTO

Certificado No. **2000103914**
 Este Certificado número 4 Certificado número: 2000103912
 Página 1 de 2

La Asociación de Normalización y Certificación, A.C., en su carácter de organismo de Certificación de Producto acreditado y aprobado en los términos de la Ley Federal sobre Metrología y Normalización (LFMN), de conformidad con los artículos 1, 2, 3, 4, 5, 6, 7, 8, 9, 10, 11, 12, 13, 14, 15, 16, 17, 18, 19, 20, 21, 22, 23, 24, 25, 26, 27, 28, 29, 30, y demás relativos y aplicables de la misma Ley, así como de su respectivo reglamento, con número de Acreditación 01/10 expedido a partir del 09/03/2010, en atención a la solicitud con número de Referencia **2000103914** de acuerdo al procedimiento de Certificación **PROPARE-01** de ANCE, otorga el presente Certificado de Conformidad de Producto a:

Título: **CORPORACIÓN MANDRINKA, S.A. DE C.V.**

Nombre genérico:	SOPORTE METALICO PARA CABLES
Especie:	MILLA
Subtipo:	CARGOLA
Material:	ACERO LINE
Categoría:	MIXTO
Modalidad:	PROCEDIMIENTO ANCE
Fabricado y/o importado por:	CORPORACIÓN MANDRINKA, S.A. DE C.V.
Dirigido a:	ALEJANDRO VOLTA No. 113 INT. SN COB. PARQUE IND. CUAMATLA DEL. CUAUTITLÁN MICHAEL P. SANCHEZ DE MENDOZA
Fábrica:	ALEJANDRO VOLTA No. 113 INT. SN COB. PARQUE IND. CUAMATLA DEL. CUAUTITLÁN MICHAEL P. SANCHEZ DE MENDOZA
País de origen:	MEXICO
Modelo:	CL (SEGUNDO O NO-CL)
Especificaciones:	MATERIAL: ACERO GALVANIZADO ELECTROLITICO ESPACIAMIENTO ENTRE APOYOS: 1.80 m DIMENSIONES: LARGO: 400 mm ANCHO: 80 mm CLASIFICACION: 08B

PROCESO 01

Submittent Laboratories Inc.

File: 803208 Rev. 3 Revised: 12/11/12 03
 100 Westborough Road
 Suite 101, 1170 West 2nd
 Street
 Westborough, MA 01581
 Telephone: 508-861-2071

File: 803208 Rev. 3 Revised: 12/11/12 03
 100 Westborough Road
 Suite 101, 1170 West 2nd
 Street
 Westborough, MA 01581
 Telephone: 508-861-2071

WILLIAM OF SERVICE INCORPORATED
 (FORM 80)

Client: WILLIAM OF SERVICE

Manufacturer: CROSS LINE
 120000-002 ALEJANDRO VOLTA, C/O E 2
 BARRIO INDUSTRIAL, CUAMATLA DEL
 CUAUTITLAN, ESTADO DE MEXICO

Application: CORPORACION MANDRINKA S A DE C V
 120000-1001 CALLE ALUMBR 101-A
 COL. BARRIO INDUSTRIAL
 BARRIO INDUSTRIAL, CUAMATLA DEL
 CUAUTITLAN, ESTADO DE MEXICO

Quantity Ordered: 5000 AS APPLICABLE
 120000-1001

This Procedure authorizes the above manufacturer to use the marking specified by Submittent Laboratories Inc. only in products covered by this Procedure, in accordance with the applicable Follow-Up Service Agreement.

The guaranteed Mark or Markings shall be used only at the above manufacturing location in any products which comply with this Procedure and any other applicable requirements.

The Procedure contains information for the use of the above named Manufacturer and representatives of Submittent Laboratories Inc. and is not to be used for any other purpose. It is loaned to the Manufacturer with the understanding that it is not to be copied, either wholly or in part, and that it will be returned to Submittent Laboratories Inc. upon request.

This PROCEDURE, and any subsequent variations, is the property of SUBMITTENT LABORATORIES INC. and is not transferable.

SUBMITTENT LABORATORIES INC.

Jason Andrews
 Chief Operating Officer

At Submittent Laboratories, we are committed to providing you with the highest quality products and services.

CERTIFICADO DE CONFORMIDAD DE PRODUCTO

Certificado No. **2000103913**
 Este Certificado número 4 Certificado número: 2000103912
 Página 1 de 2

La Asociación de Normalización y Certificación, A.C., en su carácter de organismo de Certificación de Producto acreditado y aprobado en los términos de la Ley Federal sobre Metrología y Normalización (LFMN), de conformidad con los artículos 1, 2, 3, 4, 5, 6, 7, 8, 9, 10, 11, 12, 13, 14, 15, 16, 17, 18, 19, 20, 21, 22, 23, 24, 25, 26, 27, 28, 29, 30, y demás relativos y aplicables de la misma Ley, así como de su respectivo reglamento, con número de Acreditación 01/10 expedido a partir del 09/03/2010, en atención a la solicitud con número de Referencia **2000103913** de acuerdo al procedimiento de Certificación **PROPARE-01** de ANCE, otorga el presente Certificado de Conformidad de Producto a:

Título: **CORPORACIÓN MANDRINKA, S.A. DE C.V.**

Nombre genérico:	SOPORTE PARA CABLES
Especie:	ESCALERA
Subtipo:	RENGLON
Material:	CROSS LINE
Categoría:	MIXTO
Modalidad:	PROCEDIMIENTO ANCE
Fabricado y/o importado por:	CORPORACIÓN MANDRINKA, S.A. DE C.V.
Dirigido a:	ALEJANDRO VOLTA No. 113 INT. SN COB. PARQUE IND. CUAMATLA DEL. CUAUTITLÁN MICHAEL P. SANCHEZ DE MENDOZA
Fábrica:	ALEJANDRO VOLTA No. 113 INT. SN COB. PARQUE IND. CUAMATLA DEL. CUAUTITLÁN MICHAEL P. SANCHEZ DE MENDOZA
País de origen:	MEXICO
Modelo:	CR-CL, CR (SEGUNDO O NO-CL)
Especificaciones:	MATERIAL (CARGOLA) ALUMBRINO 80B ESPACIAMIENTO ENTRE TRAVESAJES: 220.0 mm ESPACIAMIENTO ENTRE APOYOS: 2.40 m DIMENSIONES: LARGO: 1.80 m ANCHO: 101.0 mm, 914.0 mm CLASIFICACION: 8A

PROCESO 01

CERTIFICADO DE CONFORMIDAD DE PRODUCTO

Certificado No. **2000103915**
 Este Certificado número 4 Certificado número: 2000103912
 Página 1 de 2

La Asociación de Normalización y Certificación, A.C., en su carácter de organismo de Certificación de Producto acreditado y aprobado en los términos de la Ley Federal sobre Metrología y Normalización (LFMN), de conformidad con los artículos 1, 2, 3, 4, 5, 6, 7, 8, 9, 10, 11, 12, 13, 14, 15, 16, 17, 18, 19, 20, 21, 22, 23, 24, 25, 26, 27, 28, 29, 30, y demás relativos y aplicables de la misma Ley, así como de su respectivo reglamento, con número de Acreditación 01/10 expedido a partir del 09/03/2010, en atención a la solicitud con número de Referencia **2000103915** de acuerdo al procedimiento de Certificación **PROPARE-01** de ANCE, otorga el presente Certificado de Conformidad de Producto a:

Título: **CORPORACIÓN MANDRINKA, S.A. DE C.V.**

Nombre genérico:	SOPORTE METALICO PARA CABLES
Especie:	ESCALERA
Subtipo:	RENGLON
Material:	CROSS LINE
Categoría:	MIXTO
Modalidad:	PROCEDIMIENTO ANCE
Fabricado y/o importado por:	CORPORACIÓN MANDRINKA, S.A. DE C.V.
Dirigido a:	ALEJANDRO VOLTA No. 113 INT. SN COB. PARQUE IND. CUAMATLA DEL. CUAUTITLÁN MICHAEL P. SANCHEZ DE MENDOZA
Fábrica:	ALEJANDRO VOLTA No. 113 INT. SN COB. PARQUE IND. CUAMATLA DEL. CUAUTITLÁN MICHAEL P. SANCHEZ DE MENDOZA
País de origen:	MEXICO
Modelo:	CR-CL, CR (SEGUNDO O NO-CL)
Especificaciones:	MATERIAL (CARGOLA) ALUMBRINO 80B ESPACIAMIENTO ENTRE TRAVESAJES: 220.0 mm ESPACIAMIENTO ENTRE APOYOS: 2.40 m DIMENSIONES: LARGO: 1.80 m ANCHO: 101.0 mm, 914.0 mm CLASIFICACION: 8C

PROCESO 01

CABLE TRAYS Cross Line Products



Se considera un sistema de soportería tipo charola para cable a una estructura rígida y continua especialmente construida para soportar cables, tubos u otras canalizaciones, las cuales pueden ser de metal u otros materiales no combustibles.

Las charolas para cables CROSS LINE pueden usarse para soportar cables de fuerza, alumbrado, control y señalización que cuenten con aislamiento y cubierta apropiados para este tipo de instalación.

Las charolas CROSS LINE se encuentran disponibles en materiales y acabados adecuados para su instalación a la intemperie o en condiciones ambientales desfavorables.

No se permite su instalación en cubos de ascensores o en aquellos lugares donde estén expuestos a daños mecánicos severos o en áreas clasificadas de acuerdo a los artículos del 500 al 505 de la norma NOM-001 SEDE 2012, a menos que los cables estén aprobados para tal uso.

Las charolas para cables de CROSS LINE cuentan con la suficiente rigidez y resistencia mecánica para proporcionar un soporte adecuado a todo el cableado tendido dentro de ellas.

CROSS LINE cuenta con una amplia gama de charolas metálicas protegidas contra la corrosión, así como no metálicas e incluyen todos los accesorios necesarios para realizar cambios de dirección o de nivel requeridos durante la instalación.

Todas las labores de diseño y fabricación de las charolas CROSS LINE se realizan apegados a las normas tanto nacionales (NMX-J511-ANCE-2011, NOM-001 SEDE 2012) como internacionales (NEMA VE 1-2002, National Electrical Code NEC).

De esta manera el cálculo de las características de un sistema de soportería, tal como ancho, alturas, radios, distancia entre travesaños, etc. Deberá apegarse al artículo 318 de la norma NOM-001 SEDE 2012 o su similar en el código NEC.

El propósito de este catálogo de soportería para cables es el de ayudar a Ingenieros, Proyectistas y Compradores en la selección del material idóneo que cumpla con las características obtenidas en los cálculos indicados en las normas.

Debido a nuestra política de mejora continua de nuestros productos, las especificaciones, dimensiones, así como toda información contenida en este catálogo podrá ser modificada sin previo aviso.

Estamos seguros de que las ventajas que usted encontrará en nuestro sistema de soportería para cables, le convencerán de que:

¡¡¡EN CHAROLAS SEGUIMOS SIENDO LA MEJOR OPCIÓN!!!

A cable tray system is considered as a rigid and continuous metallic structure or other type of non-flammable materials which are built specially to support cable, pipes or others types of electrical channels.

CROSS LINE cable trays can be used as support of different cable type such as power, lighting systems, control or data signals. The cable must have the proper insulation according to the installation type.

CROSS LINE cable trays are available in materials and finishes for outdoors or hostile environment conditions.

Cable tray systems can't be installed in elevators shafts or areas exposed to mechanical damage.

Cable tray systems can't be installed in hazardous locations as indicated in articles 500 to 505 of the NEC code unless use a cable approved for this areas.

CROSS LINE cable tray systems are rigid and high mechanical resistance for a proper support of all cables contained inside.

CROSS LINE offers a wide range of cable trays like corrosion resistance metallic systems and non-metallic system, both have the necessary fitting for direction and level changes to offer a complete installation service.

The entire CROSS LINE cable tray's manufacturing processes, from design to finish are under Mexican (NMX-J511-ANCE-2011, NOM-001 SEDE 2012) as International (NEMA VE 1-2002, National Electrical Code NEC) standards.

So the calculation of cable tray parameters such as width, height, radius, distance between rungs and others, should be according to 318 article of NEC code or NOM-001 SEDE 2012 in Mexico.

This cable tray systems catalog is designed to help general engineers, project engineers and customers for a right cable tray selection, to fulfill the requirements obtained of the standard calculations.

CROSS LINE have a "continuous best product" policy, so the dimensions, specifications and all technical information showed in this catalog can change without notice.

While every effort has been made to assure the accuracy of information contained in this catalog at the time of publication, we cannot accept responsibility for inaccuracies resulting from undetected errors or omissions.

We are sure that the advantages of our cable tray system will convince you that:

IN CABLE TRAY SYSTEMS CROSS LINE IS YOUR BEST CHOICE!!!

Cargas soportadas

Los sistemas de soportería para cables CROSS LINE al ser diseñados y fabricados bajo la normativa nacional e internacional cumplen con las características de carga indicadas en dichas normas.

Para tal efecto en las siguientes páginas del catálogo se indicará la clasificación requerida por la norma NMX-J-511-ANCE-2011.

Esta norma indica que las cargas soportadas por los sistemas de soportería para cables (de manera principal los tramos rectos) deberán ser declaradas por el fabricante y/o vendedor.

Tomando en cuenta las pruebas declaradas en la norma. La cargas de trabajo admisibles (CTA) están dadas en función del sistema de apoyo, de donde: un sistema continuo de 2 o más charolas son probadas, colocando una carga uniforme a todo lo largo de la charola.

En lo correspondiente a las pruebas de carga admitidas por la norma, la prueba tipo VI da por valido que el fabricante pueda recomendar al instalador la longitud máxima entre apoyos, garantizando así el trabajo mecánico del soporte para cable.

Asimismo la posición de las uniones con respecto al soporte es un factor que el vendedor podrá recomendar al instalador cuando sea un caso desfavorable en la obra.

La carga de seguridad del sistema es la carga destructiva dividida entre un factor de seguridad mínimo de 1.5.

Opcionalmente podrá aplicarse una carga concentrada al centro de la distancia entre apoyos, la magnitud de esta carga deberá ser determinada por el cliente e informada a CROSS LINE para realizar los estudios de factibilidad correspondientes.

Load capacity

CROSS LINE cable tray systems are designed following the standard concepts, covering the required characteristics in load capacity.

In the catalog's following pages the classification required for the standard NMX-J-511-ANCE-2011 is shown.

This standard indicates that the system supported load (straight sections mainly) will be declared by the manufacturer and/or salesman.

Taking into account the tests declared in the norm. The acceptable workloads (CTA) are given in function of the supporting system, where: a continuous system of 2 or more cable trays are tested, placing a uniformly distributed load all along the tray.

According to standards, admitted load tests, type III test justify the manufacturer recommend to the installer, the maximum distance between supports, guaranteeing the support mechanical work.

Also the joints position with regard to the support is a factor that the salesman can suggest to the installer when adverse work conditions.

The working load is equivalent to the destruction load divided by a 1.5 safety factor.

A concentrated static load is not included in load/span designations but if it is required for the user it should be applied at the center of the span. If the combined load exceeds the working load, CROSS LINE technical department should be consulted.

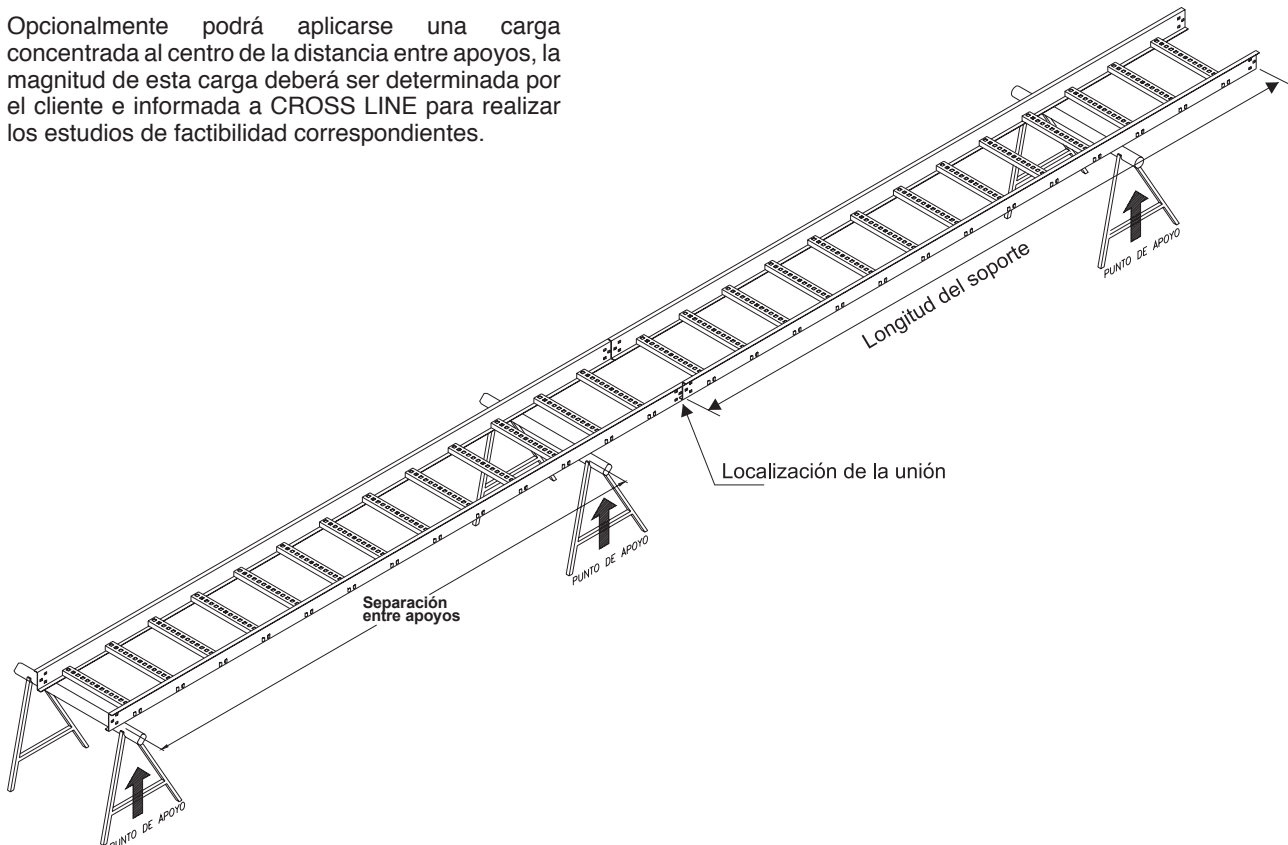

Sección 4.1

Soportería para cables tipo escalera

Section 4.1

Ladder type cable tray systems

Secciones tipo "Z" • "Z" form sections

Peralte Nominal <i>Side rail height</i>	Peralte Útil <i>Loading Depth</i>	Sufijo p/peralte <i>Rail height Suffix</i>	Clase NEMA <i>NEMA Class</i>	
			Aluminio <i>Aluminum</i>	Acero <i>Steel</i>
82.5 (3.25)	58.1 (2.29)	1	8A	12C/16B
82.5 (3.25)	56.5 (2.22)	1	8C	
101.6 (4)	75.6 (2.98)	2	12A	12C/16A
101.6 (4)	75.6 (2.98)	2	12B	
114.3 (4.5)	88.3 (3.48)	3	12B	12C/16A
127.0 (5)	101.4 (3.98)	5	12C	20A
152.4 (6)	126.4 (4.98)	6	16C	20C
177.8 (7)	151.9 (5.98)	7	12A	20A

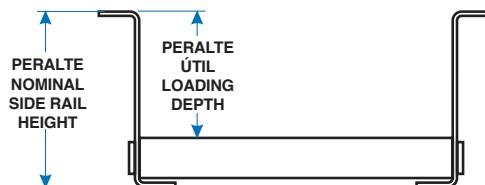

Secciones tipo "C" con ceja hacia adentro • Flange in "C" form sections

Peralte Nominal <i>Side rail height</i>	Peralte Útil <i>Loading Depth</i>	Sufijo p/peralte <i>Rail height Suffix</i>	Clase NEMA <i>NEMA Class</i>	
			Aluminio <i>Aluminum</i>	Acero <i>Steel</i>
82.5 (3.25)	58.1 (2.29)	1	12A	12B
101.6 (4)	75.6 (2.98)	2	12B	12C/16A
114.3 (4.5)	88.3 (3.48)	3	12A	12C/16A
127.0 (5)	101.4 (3.98)	5	12A	16B
152.4 (6)	126.4 (4.98)	6	16C	20B
152.4 (6)	126.4 (4.98)	6	20C	

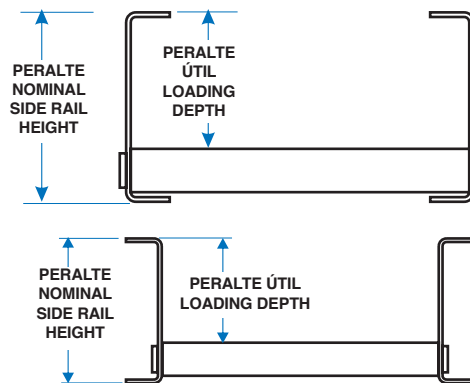

Las charolas con perfil "C" con el patín hacia afuera son solicitadas por escrito.
Flanged out "C" rail cable trays are requested in the purchase order.

Secciones tipo "I" • "I" Form sections

Peralte Nominal <i>Side rail height</i>	Peralte Útil <i>Loading Depth</i>	Sufijo p/peralte <i>Rail height Suffix</i>	Clase NEMA <i>NEMA Class</i>
			Aluminio <i>Aluminum</i>
101.6 (4)	75.6 (2.98)	2	8A
104.6 (4.120)	78.6 (3.10)	2	12B
106.7 (4.200)	80.7 (3.17)	2	12C/16A
127 (5)	101.4 (3.98)	5	12C/16A
152.4 (6)	126.4 (4.98)	6	12C/16A
152.4 (6)	126.4 (4.98)	6	20B/20C

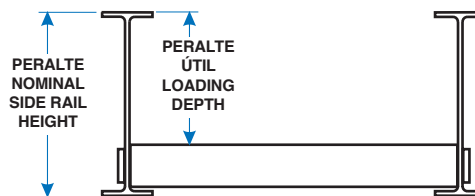

Perfil "I" solo en Aluminio • I form Aluminum only

Materiales y acabados:

A: Aluminio acabado natural
GI: Acero al carbón galvanizado por inmersión/ Lámina galvanizada
GE: Acero al carbón galvanizado electrolítico
T: Acero al carbón galvanizado tropicalizado
PVC: Acero al carbón recubierto con PVC
PVA: Aluminio recubierto con PVC
AI: Acero inoxidable
 Para materiales y acabados no indicados consulte nuestro departamento de ingeniería.
 Todas las Dimensiones en mm (pulg)

Materials & finishes:

A: AA-6063 Natural finished aluminum
GI: Hot dip galvanized steel / Galvanized sheet
GE: Electro galvanized steel
T: Chromium-zinc coated steel
PVC: PVC coated steel
PVA: PVC coated aluminum
AI: Stainless steel
 For materials and finishes not shown please consult our technical department.
 Dimensions are in mm (in)

Tramo recto • Straight section

CH Z - 1209-1GI

- Material y acabado (ver pag 58) • *Material & finishes (see page 58)*
- Sufijo p/peralte • *Rail height suffix*
- Paso • *Rung spacing*
- Ancho • *Width*
- Perfil tipo (ver pag 58) • *Rail type (see page 58)*
- Tramo recto • *Straight section*

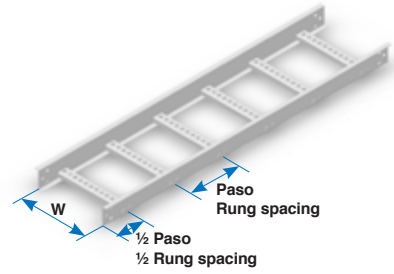

Perfil tipo Rail type	Material y acabado Material and finish						
	A	GI	GE	T	PVC	PVA	AI
Z	3.05 (10')	3.66 (12')	3.05 (10')	3.05 (10')	3.05 (10')	3.05 (10')	3.05 (10')
C	3.66 (12')	3.66 (12')	3.05(10')	3.05(10')	3.05(10')	3.05(10')	3.05(10')
I	6.10 (20')					3.05(10')	

Longitudes estándar en metros (pies) • *Standard length in meters (feet)*

Para longitudes diferentes consulte nuestro departamento de ingeniería • *For other lengths please refer to our technical department*

Ancho W Width W	Paso Rung spacing			Paso Rung spacing			Paso Rung spacing		
	152.4 (6)	228.6 (9)	304.8 (12)	152.4 (6)	228.6 (9)	304.8 (12)	152.4 (6)	228.6 (9)	304.8 (12)
101.6 (4)	CH-0406	CH-0409	CH-0412	CHC-0406	CHC-0409	CHC-0412	CHI-0406	CHI-0409	CHI-0412
152.4 (6)	CH-0606	CH-0609	CH-0612	CHC-0606	CHC-0609	CHC-0612	CHI-0606	CHI-0609	CHI-0612
228.9 (9)	CH-0906	CH-0909	CH-0912	CHC-0906	CHC-0909	CHC-0912	CHI-0906	CHI-0909	CHI-0912
304.8 (12)	CH-1206	CH-1209	CH-1212	CHC-1206	CHC-1209	CHC-1212	CHI-1206	CHI-1209	CHI-1212
406.4 (16)	CH-1606	CH-1609	CH-1612	CHC-1606	CHC-1609	CHC-1612	CHI-1606	CHI-1609	CHI-1612
457.2 (18)	CH-1806	CH-1809	CH-1812	CHC-1806	CHC-1809	CHC-1812	CHI-1806	CHI-1809	CHI-1812
508.0 (20)	CH-2006	CH-2009	CH-2012	CHC-2006	CHC-2009	CHC-2012	CHI-2006	CHI-2009	CHI-2012
609.6 (24)	CH-2406	CH-2409	CH-2412	CHC-2406	CHC-2409	CHC-2412	CHI-2406	CHI-2409	CHI-2412
762.0 (30)	CH-3006	CH-3009	CH-3012	CHC-3006	CHC-3009	CHC-3012	CHI-3006	CHI-3009	CHI-3012
914.4 (36)	CH-3606	CH-3609	CH-3612	CHC-3606	CHC-3609	CHC-3612	CHI-3606	CHI-3609	CHI-3612

Todas las dimensiones en mm (pulg) • *All dimensions are in mm (in)*

Incluye 2 conectores y tornillería • *Two connectors and hardware included*

Pasos disponibles • *Available rung spacings:*

152.4 (6), 228.6 (9), 304.8(12) y 457.2 (18)

Selección de charola.

Cable trays selection

Para seleccionar adecuadamente una charola, deberá considerar los siguientes factores:

To choose adequately a cable tray you must consider the following factors:

1) CLASE DE CHAROLA

- a) Capacidad de carga
- b) Espaciamiento entre soporte
- c) Deflexión

1) CABLE TRAY TYPE

- a) Load capacity
- b) Support's spaciousness
- c) Deflection

2) ALTURA DE CHAROLA

- a) Diámetro de cables
- b) Capacidad de relleno de cables

2) CABLE TRAY'S HEIGHT

- a) Cable's diameter
- b) Cables packing capacity

3) MATERIAL / ACABADO

- a) Medio ambiente
- b) Apariencia
- c) Costo de la instalación

3) MATERIAL / FINISH

- a) Environment
- b) Appearance
- c) Installation Cost

4) ANCHO DE CHAROLA

- a) Diámetro de cables
- b) Capacidad de relleno de cables
- c) Requerimientos para futuras expansiones

4) CABLE TRAY'S WIDE

- a) Cable's diameters
- b) Cables packing capacity
- c) Future expansion requirements

Altura de charolas • Cable tray height

Sufijo para peralte	Peralte Nominal mm (pulg.)	Peralte Útil mm (pulg.)
1	82.5 (3 1/4")	56.5 (2.224")
2	101.6 (4")	75.6 (2.976")
3	114.3 (4 1/2")	88.3 (3.476")
5	127.0 (5")	101.0 (3.976")
6	152.4 (6")	126.4 (4.976")

Curva horizontal a 45° y 90° • 45° & 90° Horizontal bend

VHZ-12R890-1 A

- Material y acabado (ver pag 58) • Material & finishes (see page 58)
- Sufijo p/peralte (ver pag 58) • Rail height suffix (see page 58)
- Ángulo de la curva • Angle bend
- Radio • Radius
- Ancho • Width
- Perfil tipo (ver pag 58) • Rail type (see page 58)
- Curva horizontal • Horizontal bend

Para curvas estructurales agregar la letra "E" después del código.

Diseño radial para perfil "Z" y "C"
Radial design for "Z" & "C" rail type

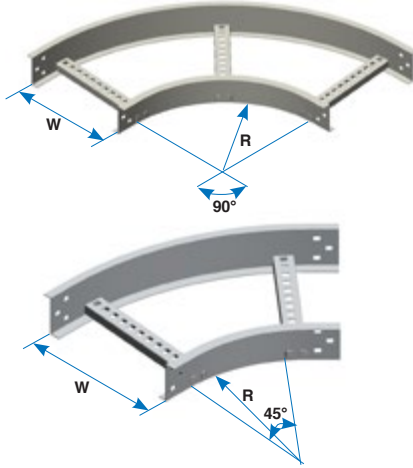

Diseño estructural para perfil "Z", "C" e "I"
Segmented design for "Z", "C" & "I" rail type

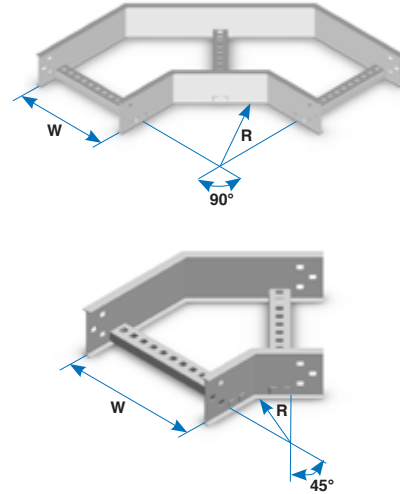

Números de catálogo para curva a 90° • 90° Bend's Catalog number

Ancho W Width W	Radio Radius			
	203.2 (8)	304.8 (12)	609.6 (24)	914.4 (36)
101.6 (4)	VH**-04R890	VH**-04R1290	VH**-04R2490	VH**-04R3690
152.4 (6)	VH**-06R890	VH**-06R1290	VH**-06R2490	VH**-06R3690
228.9 (9)	VH**-09R890	VH**-09R1290	VH**-09R2490	VH**-09R3690
304.8 (12)	VH**-12R890	VH**-12R1290	VH**-12R2490	VH**-12R3690
406.4 (16)	VH**-16R890	VH**-16R1290	VH**-16R2490	VH**-16R3690
457.2 (18)	VH**-18R890	VH**-18R1290	VH**-18R2490	VH**-18R3690
508.0 (20)	VH**-20R890	VH**-20R1290	VH**-20R2490	VH**-20R3690
609.6 (24)	VH**-24R890	VH**-24R1290	VH**-24R2490	VH**-24R3690
762.0 (30)	VH**-30R890	VH**-30R1290	VH**-30R2490	VH**-30R3690
914.4 (36)	VH**-36R890	VH**-36R1290	VH**-36R2490	VH**-36R3690

Solo radial • Radial Only

Números de catálogo para curva a 45° • 45° Bend's Catalog number

Ancho W Width W	Radio Radius			
	203.2 (8)	304.8 (12)	609.6 (24)	914.4 (36)
101.6 (4)	VH**-04R845	VH**-04R1245	VH**-04R2445	VH**-04R3645
152.4 (6)	VH**-06R845	VH**-06R1245	VH**-06R2445	VH**-06R3645
228.9 (9)	VH**-09R845	VH**-09R1245	VH**-09R2445	VH**-09R3645
304.8 (12)	VH**-12R845	VH**-12R1245	VH**-12R2445	VH**-12R3645
406.4 (16)	VH**-16R845	VH**-16R1245	VH**-16R2445	VH**-16R3645
457.2 (18)	VH**-18R845	VH**-18R1245	VH**-18R2445	VH**-18R3645
508.0 (20)	VH**-20R845	VH**-20R1245	VH**-20R2445	VH**-20R3645
609.6 (24)	VH**-24R845	VH**-24R1245	VH**-24R2445	VH**-24R3645
762.0 (30)	VH**-30R845	VH**-30R1245	VH**-30R2445	VH**-30R3645
914.4 (36)	VH**-36R845	VH**-36R1245	VH**-36R2445	VH**-36R3645

Solo radial • Radial Only

Todas las dimensiones en mm (pulg) • All dimensions are in mm (in)

Incluye 2 conectores y tornillería • Two connectors and hardware included

Curva vertical exterior a 45° Y 90° • 45° & 90° Outside vertical bend

VEZ-12R890-1 A

- Material y acabado (ver pag 58) • Material & finishes (see page 58)
- Sufijo p/peralte (ver pag 58) • Rail height suffix (see page 58)
- Ángulo de la curva • Angle bend
- Radio • Radius
- Ancho • Width
- Perfil tipo (ver pag 58) • Rail type (see page 58)
- Curva vertical exterior • Outside vertical bend

Para curvas estructurales agregar la letra "E" después del código.

Diseño radial para perfil "Z" y "C"
Radial design for "Z" & "C" rail type

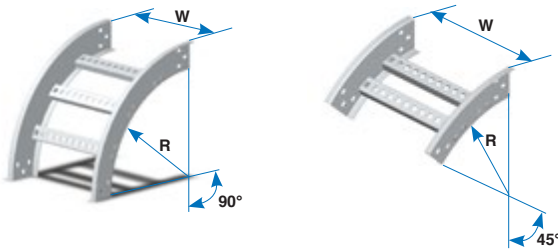

Diseño estructural para perfil "Z", "C" e "I"
Segmented design for "Z", "C" & "I" rail type

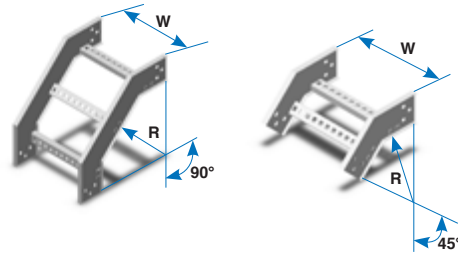

Números de catálogo para curva a 90° • 90° Bend's Catalog number

Ancho W Width W	Radio Radius			
	203.2 (8)	304.8 (12)	609.6 (24)	914.4 (36)
101.6 (4)	VE**-04R890	VE**-04R1290	VE**-04R2490	VE**-04R3690
152.4 (6)	VE**-06R890	VE**-06R1290	VE**-06R2490	VE**-06R3690
228.9 (9)	VE**-09R890	VE**-09R1290	VE**-09R2490	VE**-09R3690
304.8 (12)	VE**-12R890	VE**-12R1290	VE**-12R2490	VE**-12R3690
406.4 (16)	VE**-16R890	VE**-16R1290	VE**-16R2490	VE**-16R3690
457.2 (18)	VE**-18R890	VE**-18R1290	VE**-18R2490	VE**-18R3690
508.0 (20)	VE**-20R890	VE**-20R1290	VE**-20R2490	VE**-20R3690
609.6 (24)	VE**-24R890	VE**-24R1290	VE**-24R2490	VE**-24R3690
762.0 (30)	VE**-30R890	VE**-30R1290	VE**-30R2490	VE**-30R3690
914.4 (36)	VE**-36R890	VE**-36R1290	VE**-36R2490	VE**-36R3690

Solo radial • Radial Only

Números de catálogo para curva a 45° • 45° Bend's Catalog number

Ancho W Width W	Radio Radius			
	203.2 (8)	304.8 (12)	609.6 (24)	914.4 (36)
101.6 (4)	VE**-04R845	VE**-04R1245	VE**-04R2445	VE**-04R3645
152.4 (6)	VE**-06R845	VE**-06R1245	VE**-06R2445	VE**-06R3645
228.9 (9)	VE**-09R845	VE**-09R1245	VE**-09R2445	VE**-09R3645
304.8 (12)	VE**-12R845	VE**-12R1245	VE**-12R2445	VE**-12R3645
406.4 (16)	VE**-16R845	VE**-16R1245	VE**-16R2445	VE**-16R3645
457.2 (18)	VE**-18R845	VE**-18R1245	VE**-18R2445	VE**-18R3645
508.0 (20)	VE**-20R845	VE**-20R1245	VE**-20R2445	VE**-20R3645
609.6 (24)	VE**-24R845	VE**-24R1245	VE**-24R2445	VE**-24R3645
762.0 (30)	VE**-30R845	VE**-30R1245	VE**-30R2445	VE**-30R3645
914.4 (36)	VE**-36R845	VE**-36R1245	VE**-36R2445	VE**-36R3645

Solo radial • Radial Only

Todas las dimensiones en mm (pulg) • All dimensions are in mm (in)
Incluye 2 conectores y tornillería • Two connectors and hardware included

Curva vertical interior a 45° Y 90° • 45° & 90° Inside vertical bend

VIZ-12R890-1 A

- Material y acabado (ver pag 58) • *Material & finishes (see page 58)*
- Sufijo p/peralte (ver pag 58) • *Rail height suffix (see page 58)*
- Ángulo de la curva • *Angle bend*
- Radio • *Radius*
- Ancho • *Width*
- Perfil tipo (ver pag 58) • *Rail type (see page 58)*
- Curva vertical interior • *Inside vertical bend*

Para curvas estructurales agregar la letra "E" después del código.

Diseño radial para perfil "Z" y "C"
Radial design for "Z" & "C" rail type

Diseño estructural para perfil "Z", "C" e "I"
Segmented design for "Z", "C" & "I" rail type

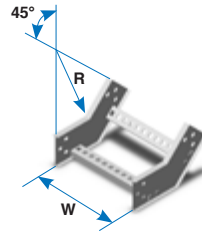
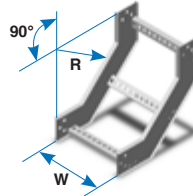
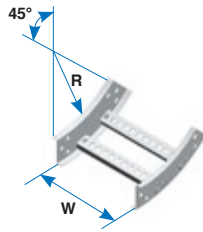
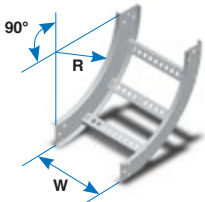

Números de catálogo para curva a 90° • 90° Bend's Catalog number

Ancho W Width W	Radio Radius			
	203.2 (8)	304.8 (12)	609.6 (24)	914.4 (36)
101.6 (4)	VI**-04R890	VI**-04R1290	VI**-04R2490	VI**-04R3690
152.4 (6)	VI**-06R890	VI**-06R1290	VI**-06R2490	VI**-06R3690
228.9 (9)	VI**-09R890	VI**-09R1290	VI**-09R2490	VI**-09R3690
304.8 (12)	VI**-12R890	VI**-12R1290	VI**-12R2490	VI**-12R3690
406.4 (16)	VI**-16R890	VI**-16R1290	VI**-16R2490	VI**-16R3690
457.2 (18)	VI**-18R890	VI**-18R1290	VI**-18R2490	VI**-18R3690
508.0 (20)	VI**-20R890	VI**-20R1290	VI**-20R2490	VI**-20R3690
609.6 (24)	VI**-24R890	VI**-24R1290	VI**-24R2490	VI**-24R3690
762.0 (30)	VI**-30R890	VI**-30R1290	VI**-30R2490	VI**-30R3690
914.4 (36)	VI**-36R890	VI**-36R1290	VI**-36R2490	VI**-36R3690

Solo radial • *Radial Only*

Números de catálogo para curva a 45° • 45° Bend's Catalog number

Ancho W Width W	Radio Radius			
	203.2 (8)	304.8 (12)	609.6 (24)	914.4 (36)
101.6 (4)	VI**-04R845	VI**-04R1245	VI**-04R2445	VI**-04R3645
152.4 (6)	VI**-06R845	VI**-06R1245	VI**-06R2445	VI**-06R3645
228.9 (9)	VI**-09R845	VI**-09R1245	VI**-09R2445	VI**-09R3645
304.8 (12)	VI**-12R845	VI**-12R1245	VI**-12R2445	VI**-12R3645
406.4 (16)	VI**-16R845	VI**-16R1245	VI**-16R2445	VI**-16R3645
457.2 (18)	VI**-18R845	VI**-18R1245	VI**-18R2445	VI**-18R3645
508.0 (20)	VI**-20R845	VI**-20R1245	VI**-20R2445	VI**-20R3645
609.6 (24)	VI**-24R845	VI**-24R1245	VI**-24R2445	VI**-24R3645
762.0 (30)	VI**-30R845	VI**-30R1245	VI**-30R2445	VI**-30R3645
914.4 (36)	VI**-36R845	VI**-36R1245	VI**-36R2445	VI**-36R3645

Solo radial • *Radial Only*

Todas las dimensiones en mm (pulg) • *All dimensions are in mm (in)*
Incluye 2 conectores y tornillería • *Two connectors and hardware included*

“T” Horizontal • Horizontal tee

THZ-12R8-1 A

- Material y acabado (ver pag 58) • *Material & finishes (see page 58)*
- Sufijo p/peralte (ver pag 58) • *Rail height suffix (see page 58)*
- Radio • *Radius*
- Ancho • *Width*
- Perfil tipo (ver pag 58) • *Rail type (see page 58)*
- “T” Horizontal • *Horizontal “T”*

Para curvas estructurales agregar la letra “E” después del código.

Diseño radial para perfil “Z” y “C”
Radial design for “Z” & “C” rail type

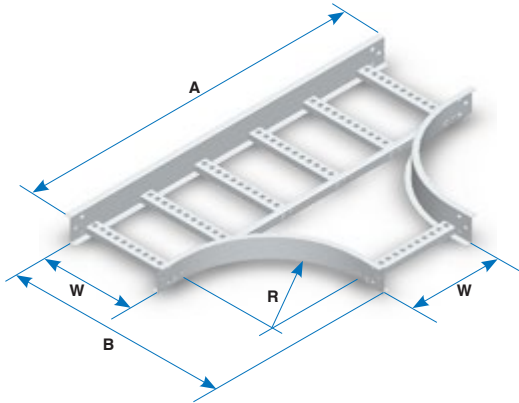

Diseño estructural para perfil “Z”, “C” e “I”
Segmented design for “Z”, “C” & “I” rail type

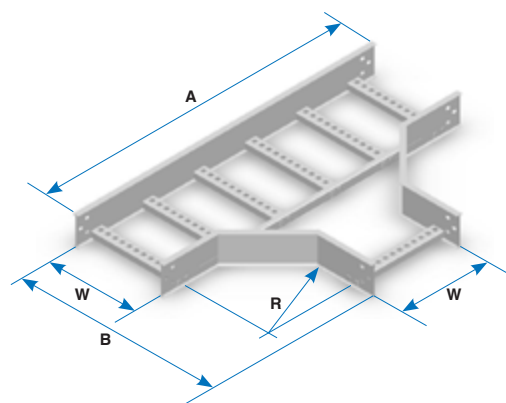

Ancho W Width W	Radio 203.2 solo radial <i>Radius (8) radial only</i>			Radio 304.8 <i>Radius (12)</i>		
	No. de catálogo <i>Catalog number</i>	A	B	No. de catálogo <i>Catalog number</i>	A	B
101.6 (4)	TH**-04R8	731 (28.78)	416 (16.39)	TH**-04R12	864 (34)	518 (20.39)
152.4 (6)	TH**-06R8	782 (30.78)	467 (18.39)	TH**-06R12	914 (36)	569 (22.39)
228.9 (9)	TH**-09R8	585 (23.03)	543 (21.39)	TH**-09R12	991 (39)	645 (25.39)
304.8 (12)	TH**-12R8	934 (36.78)	619 (24.39)	TH**-12R12	1137 (44.78)	721 (28.39)
406.4 (16)	TH**-16R8	1036 (40.78)	721 (28.39)	TH**-16R12	1239 (48.78)	823 (32.39)
457.2 (18)	TH**-18R8	1086 (42.78)	772 (30.39)	TH**-18R12	1290 (50.78)	873 (34.39)
508.0 (20)	TH**-20R8	1137 (44.78)	823 (32.39)	TH**-20R12	1341 (52.78)	924 (36.39)
609.6 (24)	TH**-24R8	1239 (48.78)	924 (36.39)	TH**-24R12	1442 (56.78)	1026 (40.39)
762.0 (30)	TH**-30R8	1391 (54.78)	1077 (42.39)	TH**-30R12	1595 (62.78)	1178 (46.39)
914.4 (36)	TH**-36R8	1543 (60.78)	1229 (48.39)	TH**-36R12	1747 (68.78)	1331 (52.39)

Ancho W Width W	Radio 609.6 <i>Radius (24)</i>			Radio 914.4 <i>Radius (36)</i>		
	No. de catálogo <i>Catalog number</i>	A	B	No. de catálogo <i>Catalog number</i>	A	B
101.6 (4)	TH**-04R24	1544 (60.78)	823 (32.39)	TH**-04R36	2153 (84.78)	1127 (44.39)
152.4 (6)	TH**-06R24	1595 (62.78)	873 (34.39)	TH**-06R36	2204 (86.78)	1178 (46.39)
228.9 (9)	TH**-09R24	1671 (65.78)	950 (37.39)	TH**-09R36	2280 (89.78)	1254 (49.39)
304.8 (12)	TH**-12R24	1747 (68.78)	1030 (40.39)	TH**-12R36	2357 (92.78)	1331 (52.39)
406.4 (16)	TH**-16R24	1849 (72.78)	1127 (44.39)	TH**-16R36	2458 (96.78)	1432 (56.39)
457.2 (18)	TH**-18R24	1899 (74.78)	1178 (46.39)	TH**-18R36	2509 (98.78)	1483 (58.39)
508.0 (20)	TH**-20R24	1950 (76.78)	1229 (48.39)	TH**-20R36	2560 (100.78)	1534 (60.39)
609.6 (24)	TH**-24R24	2052 (80.78)	1331 (52.39)	TH**-24R36	2661 (104.78)	1635 (64.39)
762.0 (30)	TH**-30R24	2204 (86.78)	1483 (58.39)	TH**-30R36	2814 (110.78)	1788 (70.39)
914.4 (36)	TH**-36R24	2357 (92.78)	1635 (64.39)	TH**-36R36	2966 (116.78)	1940 (76.39)

Todas las dimensiones en mm (pulg) • *All dimensions are in mm (in)*
Incluye 2 conectores y tornillería • *Two connectors and hardware included*

“X” Horizontal • Horizontal cross

XHZ-12R8-1 A E

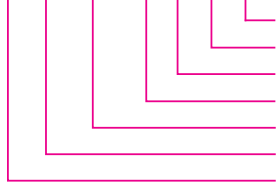

E = estructural, radial omitir • E = segmented, avoid if radial
 Material y acabado (ver pag 58) • Material & finishes (see page 58)
 Sufijo p/peralte (ver pag 58) • Rail height suffix (see page 58)
 Radio • Radius
 Ancho • Width
 Perfil tipo (ver pag 58) • Rail type (see page 58)
 “X” horizontal • Horizontal cross

Diseño radial para perfil “Z” y “C”
 Radial design for “Z” & “C” rail type

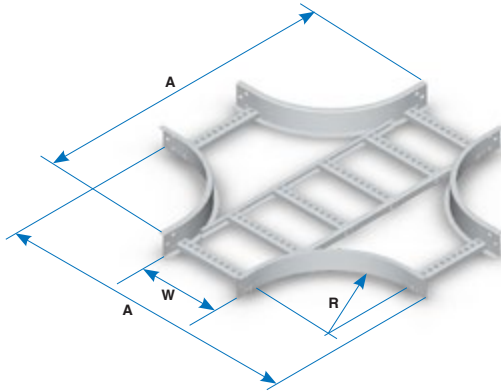

Diseño estructural para perfil “Z”, “C” e “I”
 Segmented design for “Z”, “C” & “I” rail type

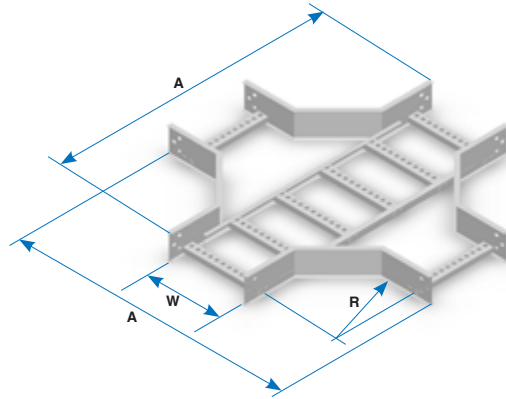

Ancho W Width W	Radio 203.2 solo radial Radius (8) radial only		Radio 304.8 Radius (12)	
	No. de catálogo Catalog number	A	No. de catálogo Catalog number	A
101.6 (4)	XH**-04R8	731 (28.78)	XH**-04R12	864 (34)
152.4 (6)	XH**-06R8	782 (30.78)	XH**-06R12	914 (36)
228.9 (9)	XH**-09R8	585 (23.03)	XH**-09R12	991 (39)
304.8 (12)	XH**-12R8	934 (36.78)	XH**-12R12	1137 (44.78)
406.4 (16)	XH**-16R8	1036 (40.78)	XH**-16R12	1239 (48.78)
457.2 (18)	XH**-18R8	1086 (42.78)	XH**-18R12	1290 (50.78)
508.0 (20)	XH**-20R8	1137 (44.78)	XH**-20R12	1341 (52.78)
609.6 (24)	XH**-24R8	1239 (48.78)	XH**-24R12	1442 (56.78)
762.0 (30)	XH**-30R8	1391 (54.78)	XH**-30R12	1595 (62.78)
914.4 (36)	XH**-36R8	1543 (60.78)	XH**-36R12	1747 (68.78)

Ancho W Width W	Radio 609.6 Radius (24)		Radio 914.4 Radius (36)	
	No. de catálogo Catalog number	A	No. de catálogo Catalog number	A
101.6 (4)	XH**-04R24	1544 (60.78)	XH**-04R36	2153 (84.78)
152.4 (6)	XH**-06R24	1595 (62.78)	XH**-06R36	2204 (86.78)
228.9 (9)	XH**-09R24	1671 (65.78)	XH**-09R36	2280 (89.78)
304.8 (12)	XH**-12R24	1747 (68.78)	XH**-12R36	2357 (92.78)
406.4 (16)	XH**-16R24	1849 (72.78)	XH**-16R36	2458 (96.78)
457.2 (18)	XH**-18R24	1899 (74.78)	XH**-18R36	2509 (98.78)
508.0 (20)	XH**-20R24	1950 (76.78)	XH**-20R36	2560 (100.78)
609.6 (24)	XH**-24R24	2052 (80.78)	XH**-24R36	2661 (104.78)
762.0 (30)	XH**-30R24	2204 (86.78)	XH**-30R36	2814 (110.78)
914.4 (36)	XH**-36R24	2357 (92.78)	XH**-36R36	2966 (116.78)

Todas las dimensiones en mm (pulg) • All dimensions are in mm (in)
 Incluye 2 conectores y tornillería • Two connectors and hardware included

“T” Vertical • Vertical tee

TVZ-12R8-1 A E

- E = estructural, radial omitir • E = segmented, avoid if radial
- Material y acabado (ver pag 58) • Material & finishes (see page 58)
- Sufijo p/peralte (ver pag 58) • Rail height suffix (see page 58)
- Radio • Radius
- Ancho • Width
- Perfil tipo (ver pag 58) • Rail type (see page 58)
- “T” Vertical • Vertical “T”

Diseño radial para perfil “Z”,
radios 203.2 y 304.8 (8 y 12)
Radial design for “Z” rail type,
radius 203.2 & 304.8 (8 & 12)

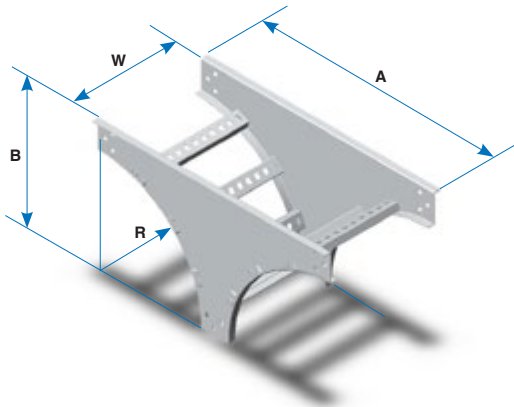

Diseño estructural para perfil “Z” y “C” radios 609.6
y 914.4 (24 y 36); perfil “I” radios 203.2, 304.8,
609.6 y 914.4 (8, 12, 24 y 36)
Segmented design for “Z” & “C” rail type radius
609.6 & 914.4 (24 & 36); “I” rail type radius 203.2,
304.8, 609.6 & 914.4 (8, 12, 24 & 36)

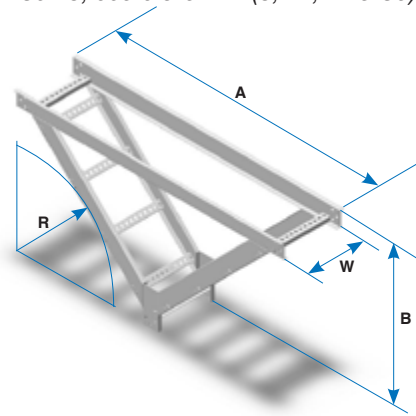

Ancho W Width W	Radio Radius			
	203.2 (8)	304.8 (12)	609.6 (24)	914.4 (36)
101.6 (4)	TV**-04R8	TV**-04R12	TV**-04R24	TV**-04R36
152.4 (6)	TV**-06R8	TV**-06R12	TV**-06R24	TV**-06R36
228.9 (9)	TV**-09R8	TV**-09R12	TV**-09R24	TV**-09R36
304.8 (12)	TV**-12R8	TV**-12R12	TV**-12R24	TV**-12R36
406.4 (16)	TV**-16R8	TV**-16R12	TV**-16R24	TV**-16R36
457.2 (18)	TV**-18R8	TV**-18R12	TV**-18R24	TV**-18R36
508.0 (20)	TV**-20R8	TV**-20R12	TV**-20R24	TV**-20R36
609.6 (24)	TV**-24R8	TV**-24R12	TV**-24R24	TV**-24R36
762.0 (30)	TV**-30R8	TV**-30R12	TV**-30R24	TV**-30R36
914.4 (36)	TV**-36R8	TV**-36R12	TV**-36R24	TV**-36R36

Sufijo p/peralte Rail height suffix	Radio Radius							
	203.2 (8)		304.8 (12)		609.6 (24)		914.4 (36)	
	A	B	A	B	A	B	A	B
1	489 (19.25)	286 (11.25)	692 (27.25)	387 (15.25)	1302 (51.25)	692 (27.25)	1911 (75.25)	997 (39.25)
2	508 (20)	305 (12)	711 (28)	406 (16)	1321 (52)	711 (28)	1930 (76)	1016 (40)
3	521 (20.5)	318 (12.5)	724 (28.5)	419 (16.5)	1334 (52.5)	724 (28.5)	1943 (76.5)	1029 (40.5)
5	533 (21)	330 (13)	737 (29)	432 (17)	1346 (53)	737 (29)	1956 (77)	1041 (41)
6	559 (22)	356 (14)	762 (30)	457 (18)	1372 (54)	762 (30)	1981 (78)	1067 (42)

Todas las dimensiones en mm (pulg) • All dimensions are in mm (in)
Incluye 2 conectores y tornillería • Two connectors and hardware included

Curva vertical para soporte • Vertical support elbow

CVGZ-12R8-1 A

- Material y acabado (ver pag 58) • *Material & finishes (see page 58)*
- Sufijo p/peralte (ver pag 58) • *Rail height suffix (see page 58)*
- Radio • *Radius*
- Ancho • *Width*
- Perfil tipo (ver pag 58) • *Rail type (see page 58)*
- Curva vertical para soporte • *Vertical support elbow*

Diseño radial para perfil “Z” y “C”,
radios 203.2 y 304.8 (8 y 12)
*Radial design for rail type Z y C,
radius 203.2 & 304.8 (8 & 12)*

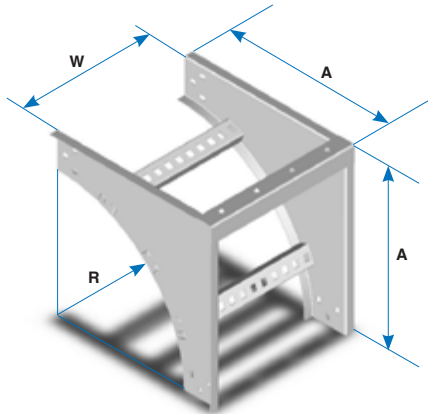

Diseño estructural para perfil “Z” y “C” radios 609.6 y
914.4 (24 y 36); perfil “I” radios 203.2, 304.8, 609.6 y
914.4 (8, 12, 24 y 36)
*Segmented design for “Z” & “C” rail type radius 609.6
& 914.4 (24 & 36); “I” rail type radius 203.2, 304.8,
609.6 & 914.4 (8, 12, 24 & 36)*

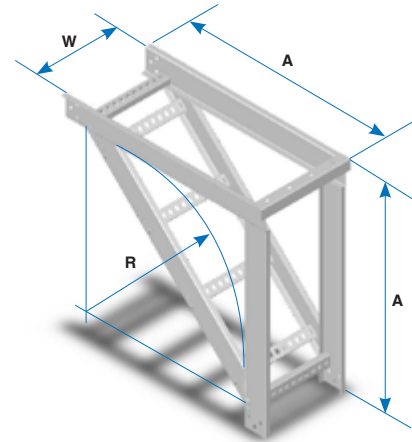

Ancho W Width W	Radio Radius				No. ganchos No. of hooks
	203.2 (8)	304.8 (12)	609.6 (24)	914.4 (36)	
101.6 (4)	CVG**-04R8	CVG**-04R12	CVG**-04R24	CVG**-04R36	2
152.4 (6)	CVG**-06R8	CVG**-06R12	CVG**-06R24	CVG**-06R36	2
228.9 (9)	CVG**-09R8	CVG**-09R12	CVG**-09R24	CVG**-09R36	4
304.8 (12)	CVG**-12R8	CVG**-12R12	CVG**-12R24	CVG**-12R36	4
406.4 (16)	CVG**-16R8	CVG**-16R12	CVG**-16R24	CVG**-16R36	6
457.2 (18)	CVG**-18R8	CVG**-18R12	CVG**-18R24	CVG**-18R36	6
508.0 (20)	CVG**-20R8	CVG**-20R12	CVG**-20R24	CVG**-20R36	8
609.6 (24)	CVG**-24R8	CVG**-24R12	CVG**-24R24	CVG**-24R36	8
762.0 (30)	CVG**-30R8	CVG**-30R12	CVG**-30R24	CVG**-30R36	12
914.4 (36)	CVG**-36R8	CVG**-36R12	CVG**-36R24	CVG**-36R36	12

Dimensión “A” • “A” Dimension

Sufijo p/peralte Rail height suffix	Radio Radius			
	203.2 (8)	304.8 (12)	609.6 (24)	914.4 (36)
	A	A	A	A
1	286	388	693	997
2	305	407	712	1016
3	317	419	724	1028
5	330	432	737	1041
6	355	457	762	1066

Todas las dimensiones en mm (pulg) • *All dimensions are in mm (in)*
Incluye 2 conectores y tornillería • *Two connectors and hardware included*

Curva horizontal ajustable • Horizontal adjustable bend

CAZ-12-1 A

- Material y acabado (ver pag 58) • Material & finishes (see page 58)
- Sufijo p/peralte (ver pag 58) • Rail height suffix (see page 58)
- Ancho • Width
- Perfil tipo (ver pag 58) • Rail type (see page 58)
- Curva horizontal ajustable • Horizontal adjustable bend

Ancho W Width W	No. de catálogo Catalog number
101.6 (4)	CA*-04
152.4 (6)	CA*-06
228.9 (9)	CA*-09
304.8 (12)	CA*-12
406.4 (16)	CA*-16
457.2 (18)	CA*-18
508.0 (20)	CA*-20
609.6 (24)	CA*-24
762.0 (30)	CA*-30
914.4 (36)	CA*-36

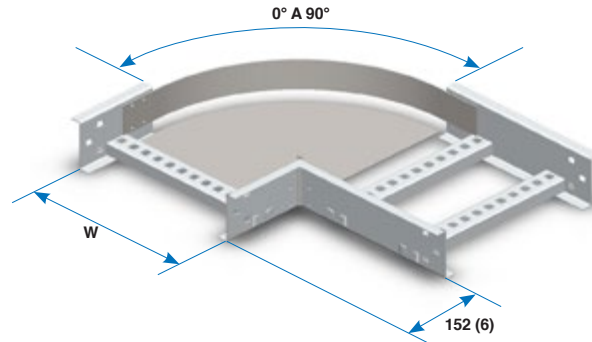

Todas las dimensiones en mm (pulg) • All dimensions are in mm (in)
 No incluye cintas conductoras • Bonding jumpers not included
 Incluye 2 conectores y tornillería • Two connectors and hardware included

Derivación horizontal a 45° • 45° Horizontal wye branch

DY * Z-12-1 A

- Material y acabado (ver pag 58) • Material & finishes (see page 58)
- Sufijo p/peralte (ver pag 58) • Rail height suffix (see page 58)
- Ancho • Width
- Perfil tipo (ver pag 58) • Rail type (see page 58)
- Colocar "D" para derecha o "I" izquierda • Add "D" for right or "I" for left
- Derivación horizontal a 45° • 45° horizontal wye branch

Ancho W Width W	No. de catálogo Catalog number	A
101.6 (4)	DY*-04	463 (18.2)
152.4 (6)	DY*-06	534 (21)
228.9 (9)	DY*-09	642 (25.3)
304.8 (12)	DY*-12	750 (29.5)
406.4 (16)	DY*-16	894 (35.2)
457.2 (18)	DY*-18	966 (38)
508.0 (20)	DY*-20	1037 (40.8)
609.6 (24)	DY*-24	1181 (46.5)
762.0 (30)	DY*-30	1396 (55)
914.4 (36)	DY*-36	1612 (63.5)

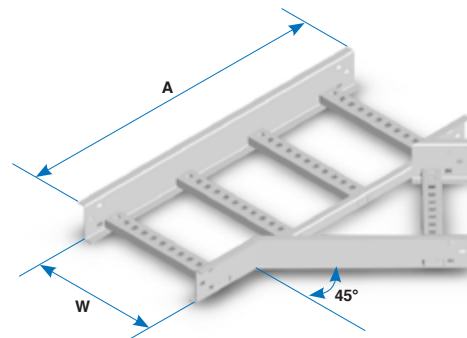

Todas las dimensiones en mm (pulg) • All dimensions are in mm (in)
 Incluye 2 conectores y tornillería • Two connectors and hardware included

Reducciones • Reducers

RL Z-1209-1 A

- Material y acabado (ver pag 58) • *Material & finishes (see page 58)*
- Sufijo p/peralte (ver pag 58) • *Rail height suffix (see page 58)*
- Ancho menor • *Smaller width*
- Ancho mayor • *Larger width*
- Perfil tipo (ver pag 58) • *Rail type (see page 58)*
- Reducción • *Reducer*
- RL = Recta • *Straight*
- RLD = Derecha • *Right*
- RLI = Izquierda • *Left*

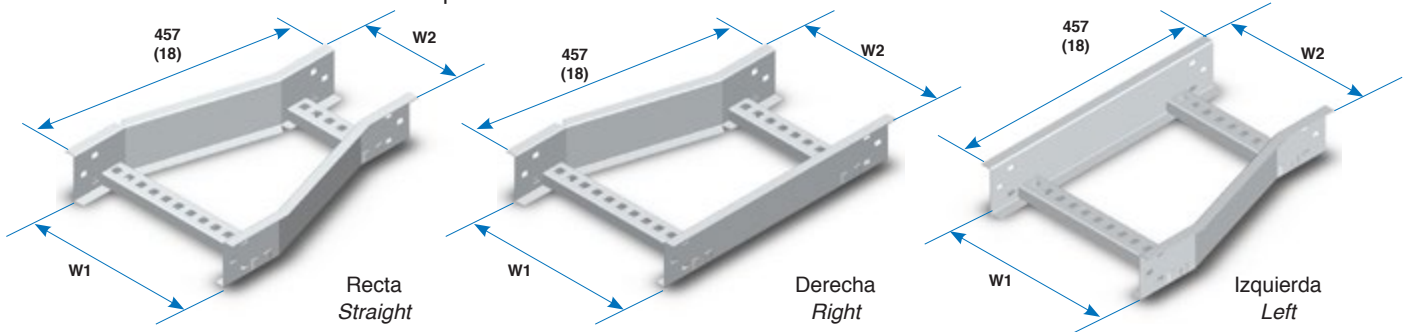

N° de catálogo reducciones rectas • *Straight reducer catalog number*

Ancho W1 Width W1	Ancho menor W2 Smaller width W2								
	101.6 (4)	152.4 (6)	228.9 (9)	304.8 (12)	406.4 (16)	457.2 (18)	508.0 (20)	609.6 (24)	762.0 (30)
152.4 (6)	RL*-0604								
228.9 (9)	RL*-0904	RL*-0906							
304.8 (12)	RL*-1204	RL*-1206	RL*-1209						
406.4 (16)	RL*-1604	RL*-1606	RL*-1609	RL*-1612					
457.2 (18)	RL*-1804	RL*-1806	RL*-1809	RL*-1812	RL*-1816				
508.0 (20)	RL*-2004	RL*-2006	RL*-2009	RL*-2012	RL*-2016	RL*-2018			
609.6 (24)	RL*-2404	RL*-2406	RL*-2409	RL*-2412	RL*-2416	RL*-2418	RL*-2420		
762.0 (30)	RL*-3004	RL*-3006	RL*-3009	RL*-3012	RL*-3016	RL*-3018	RL*-3020	RL*-3024	
914.4 (36)	RL*-3604	RL*-3606	RL*-3609	RL*-3612	RL*-3616	RL*-3618	RL*-3620	RL*-3624	RL*-3630

N° de catálogo reducciones derechas • *Right reducer catalog number*

Ancho W1 Width W1	Ancho menor W2 Smaller width W2								
	101.6 (4)	152.4 (6)	228.9 (9)	304.8 (12)	406.4 (16)	457.2 (18)	508.0 (20)	609.6 (24)	762.0 (30)
152.4 (6)	RLD*-0604								
228.9 (9)	RLD*-0904	RLD*-0906							
304.8 (12)	RLD*-1204	RLD*-1206	RLD*-1209						
406.4 (16)	RLD*-1604	RLD*-1606	RLD*-1609	RLD*-1612					
457.2 (18)	RLD*-1804	RLD*-1806	RLD*-1809	RLD*-1812	RLD*-1816				
508.0 (20)	RLD*-2004	RLD*-2006	RLD*-2009	RLD*-2012	RLD*-2016	RLD*-2018			
609.6 (24)	RLD*-2404	RLD*-2406	RLD*-2409	RLD*-2412	RLD*-2416	RLD*-2418	RLD*-2420		
762.0 (30)	RLD*-3004	RLD*-3006	RLD*-3009	RLD*-3012	RLD*-3016	RLD*-3018	RLD*-3020	RLD*-3024	
914.4 (36)	RLD*-3604	RLD*-3606	RLD*-3609	RLD*-3612	RLD*-3616	RLD*-3618	RLD*-3620	RLD*-3624	RLD*-3630

N° de catálogo reducciones izquierdas • *Left reducer catalog number*

Ancho W1 Width W1	Ancho menor W2 Smaller width W2								
	101.6 (4)	152.4 (6)	228.9 (9)	304.8 (12)	406.4 (16)	457.2 (18)	508.0 (20)	609.6 (24)	762.0 (30)
152.4 (6)	RLI*-0604								
228.9 (9)	RLI*-0904	RLI*-0906							
304.8 (12)	RLI*-1204	RLI*-1206	RLI*-1209						
406.4 (16)	RLI*-1604	RLI*-1606	RLI*-1609	RLI*-1612					
457.2 (18)	RLI*-1804	RLI*-1806	RLI*-1809	RLI*-1812	RLI*-1816				
508.0 (20)	RLI*-2004	RLI*-2006	RLI*-2009	RLI*-2012	RLI*-2016	RLI*-2018			
609.6 (24)	RLI*-2404	RLI*-2406	RLI*-2409	RLI*-2412	RLI*-2416	RLI*-2418	RLI*-2420		
762.0 (30)	RLI*-3004	RLI*-3006	RLI*-3009	RLI*-3012	RLI*-3016	RLI*-3018	RLI*-3020	RLI*-3024	
914.4 (36)	RLI*-3604	RLI*-3606	RLI*-3609	RLI*-3612	RLI*-3616	RLI*-3618	RLI*-3620	RLI*-3624	RLI*-3630

Todas las dimensiones en mm (pulg) • *All dimensions are in mm (in)*
 Incluye 2 conectores y tornillería • *Two connectors and hardware included*

Sección 4.2

Soportería para cables tipo fondo sólido y fondo ventilado

Section 4.2

Solid and ventilated trough type cable tray system

Secciones tipo "Z" • Form "Z" sections

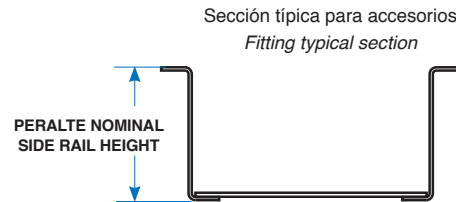
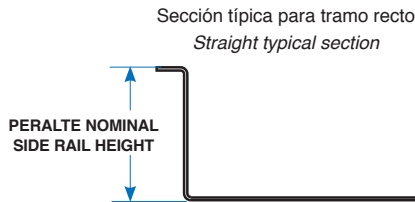

Secciones tipo "C" • Form "C" sections

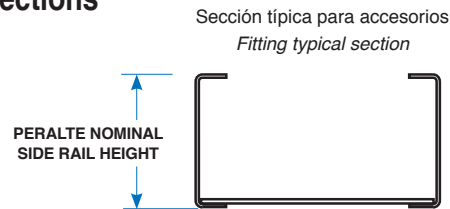
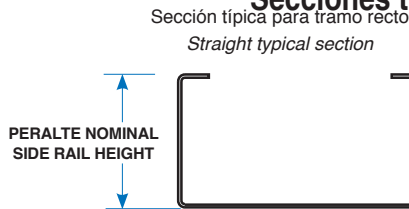

Sufijo para peralte	Peralte Nominal mm (pulg.)	Peralte Útil mm (pulg.)
0	50.8 (2")	50.8 (2")
1	82.5 (3 1/4")	82.5 (3 1/4")
2	101.6 (4")	101.6 (4")
3	114.3 (4 1/2")	114.3 (4 1/2")
5	127.0 (5")	127.0 (5")
6	152.4 (6")	152.4 (6")

Tramo recto • Straight section

CHZP-12-1 A

- Material y acabado • Material & finishes
- Sufijo p/peralte • Rail height suffix
- Ancho • Width
- Tipo de fondo • Trough type
- Tramo recto • Straight section

Ancho W Width W	Perfil tipo Z Form Z		Perfil tipo C C Form	
	Liso Solid	Ventilado Ventilated	Liso Solid	Ventilado Ventilated
101.6 (4)	CHZL-04	CHZP-04	CHCL-04	CHCP-04
152.4 (6)	CHZL-06	CHZP-06	CHCL-06	CHCP-06
228.9 (9)	CHZL-09	CHZP-09	CHCL-09	CHCP-09
304.8 (12)	CHZL-12	CHZP-12	CHCL-12	CHCP-12
406.4 (16)	CHZL-16	CHZP-16	CHCL-16	CHCP-16
457.2 (18)	CHZL-18	CHZP-18	CHCL-18	CHCP-18
508.0 (20)	CHZL-20	CHZP-20	CHCL-20	CHCP-20
609.6 (24)	CHZL-24	CHZP-24	CHCL-24	CHCP-24
762.0 (30)	CHZL-30	CHZP-30	CHCL-30	CHCP-30
914.4 (36)	CHZL-36	CHZP-36	CHCL-36	CHCP-36

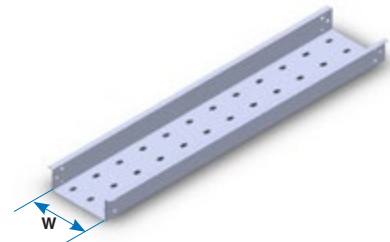

Longitud estándar 3.05 m (10 ft).
Para longitudes diferentes consulte
nuestro departamento de ingeniería.

Standard length 3.05 m (10 ft).
For other lengths refer to our
technical department.

Incluye 2 conectores y tornillería • Two connectors and hardware included

Materiales y acabados:

- A:** Aluminio aleación AA 3003 acabado natural
- GI:** Acero al carbón galvanizado por inmersión/ Lámina galvanizada
- GE:** Acero al carbón Galvanizado electrolítico
- T:** Acero al carbón Tropicalizado
- AI:** Acero inoxidable

Para materiales y acabados no indicados consulte nuestro departamento de ingeniería.

Todas las dimensiones en mm (pulg)

Materials & finishes:

- A:** AA-3003 natural finished aluminum
- GI:** Hot dip galvanized steel/ Galvanized sheet
- GE:** Electro galvanized steel
- T:** Chromium-zinc coated steel
- AI:** Stainless steel

For materials and finishes not shown please consult our technical department.

All dimensions are in mm (in)

Curva horizontal a 45° y 90° • 45° & 90° Horizontal bend

VHZP-12R890-1 A

- Material y acabado (ver pag 69) • *Material & finishes (see page 69)*
- Sufijo p/peralte (ver pag 69) • *Rail height suffix (see page 69)*
- Ángulo de la curva • *Angle bend*
- Radio • *Radius*
- Ancho • *Width*
- Tipo de fondo y perfil (ver pag 69) • *Rail & trough type (see page 69)*
- Curva horizontal • *Horizontal bend*

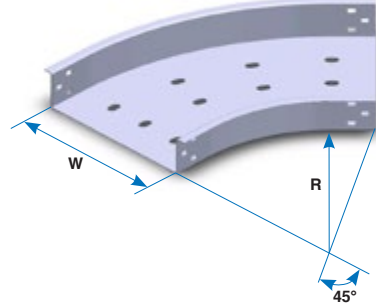
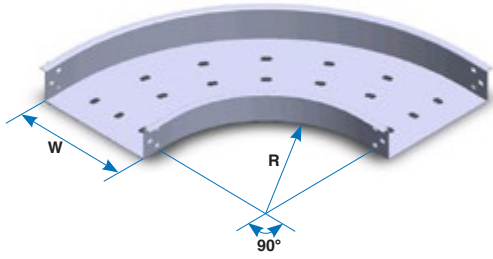

Números de catálogo para curva a 90° • 90° Bend's Catalog number

Ancho W Width W	Radio Radius			
	203.2 (8)	304.8 (12)	609.6 (24)	914.4 (36)
101.6 (4)	VH**-04R890	VH**-04R1290	VH**-04R2490	VH**-04R3690
152.4 (6)	VH**-06R890	VH**-06R1290	VH**-06R2490	VH**-06R3690
228.9 (9)	VH**-09R890	VH**-09R1290	VH**-09R2490	VH**-09R3690
304.8 (12)	VH**-12R890	VH**-12R1290	VH**-12R2490	VH**-12R3690
406.4 (16)	VH**-16R890	VH**-16R1290	VH**-16R2490	VH**-16R3690
457.2 (18)	VH**-18R890	VH**-18R1290	VH**-18R2490	VH**-18R3690
508.0 (20)	VH**-20R890	VH**-20R1290	VH**-20R2490	VH**-20R3690
609.6 (24)	VH**-24R890	VH**-24R1290	VH**-24R2490	VH**-24R3690
762.0 (30)	VH**-30R890	VH**-30R1290	VH**-30R2490	VH**-30R3690
914.4 (36)	VH**-36R890	VH**-36R1290	VH**-36R2490	VH**-36R3690

Números de catálogo para curva a 45° • 45° Bend's Catalog number

Ancho W Width W	Radio Radius			
	203.2 (8)	304.8 (12)	609.6 (24)	914.4 (36)
101.6 (4)	VH**-04R845	VH**-04R1245	VH**-04R2445	VH**-04R3645
152.4 (6)	VH**-06R845	VH**-06R1245	VH**-06R2445	VH**-06R3645
228.9 (9)	VH**-09R845	VH**-09R1245	VH**-09R2445	VH**-09R3645
304.8 (12)	VH**-12R845	VH**-12R1245	VH**-12R2445	VH**-12R3645
406.4 (16)	VH**-16R845	VH**-16R1245	VH**-16R2445	VH**-16R3645
457.2 (18)	VH**-18R845	VH**-18R1245	VH**-18R2445	VH**-18R3645
508.0 (20)	VH**-20R845	VH**-20R1245	VH**-20R2445	VH**-20R3645
609.6 (24)	VH**-24R845	VH**-24R1245	VH**-24R2445	VH**-24R3645
762.0 (30)	VH**-30R845	VH**-30R1245	VH**-30R2445	VH**-30R3645
914.4 (36)	VH**-36R845	VH**-36R1245	VH**-36R2445	VH**-36R3645

Incluye 2 conectores y tornillería • *Two connectors and hardware included*
 Todas las dimensiones en mm (pulg) • *All dimensions are in mm (in)*

Curva vertical exterior a 45° y 90° • 45° & 90° Outside vertical bend

VEZP-12R890-1 A

Material y acabado (ver pag 69) • *Material & finishes (see page 69)*
 Sufijo p/peralte (ver pag 69) • *Rail height suffix (see page 69)*
 Ángulo de la curva • *Angle bend*
 Radio • *Radius*
 Ancho • *Width*
 Tipo de fondo y perfil (ver pag 69) • *Rail & trough type (see page 69)*
 Curva vertical exterior • *Outside vertical bend*

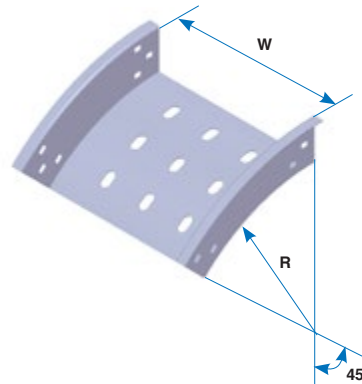
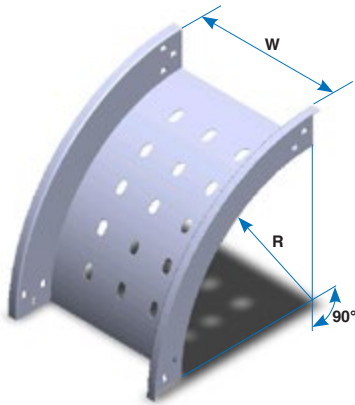

Números de catálogo para curva a 90° • 90° Bend's Catalog number

Ancho W Width W	Radio Radius			
	203.2 (8)	304.8 (12)	609.6 (24)	914.4 (36)
101.6 (4)	VE**-04R890	VE**-04R1290	VE**-04R2490	VE**-04R3690
152.4 (6)	VE**-06R890	VE**-06R1290	VE**-06R2490	VE**-06R3690
228.9 (9)	VE**-09R890	VE**-09R1290	VE**-09R2490	VE**-09R3690
304.8 (12)	VE**-12R890	VE**-12R1290	VE**-12R2490	VE**-12R3690
406.4 (16)	VE**-16R890	VE**-16R1290	VE**-16R2490	VE**-16R3690
457.2 (18)	VE**-18R890	VE**-18R1290	VE**-18R2490	VE**-18R3690
508.0 (20)	VE**-20R890	VE**-20R1290	VE**-20R2490	VE**-20R3690
609.6 (24)	VE**-24R890	VE**-24R1290	VE**-24R2490	VE**-24R3690
762.0 (30)	VE**-30R890	VE**-30R1290	VE**-30R2490	VE**-30R3690
914.4 (36)	VE**-36R890	VE**-36R1290	VE**-36R2490	VE**-36R3690

Números de catálogo para curva a 45° • 45° Bend's Catalog number

Ancho W Width W	Radio Radius			
	203.2 (8)	304.8 (12)	609.6 (24)	914.4 (36)
101.6 (4)	VE**-04R845	VE**-04R1245	VE**-04R2445	VE**-04R3645
152.4 (6)	VE**-06R845	VE**-06R1245	VE**-06R2445	VE**-06R3645
228.9 (9)	VE**-09R845	VE**-09R1245	VE**-09R2445	VE**-09R3645
304.8 (12)	VE**-12R845	VE**-12R1245	VE**-12R2445	VE**-12R3645
406.4 (16)	VE**-16R845	VE**-16R1245	VE**-16R2445	VE**-16R3645
457.2 (18)	VE**-18R845	VE**-18R1245	VE**-18R2445	VE**-18R3645
508.0 (20)	VE**-20R845	VE**-20R1245	VE**-20R2445	VE**-20R3645
609.6 (24)	VE**-24R845	VE**-24R1245	VE**-24R2445	VE**-24R3645
762.0 (30)	VE**-30R845	VE**-30R1245	VE**-30R2445	VE**-30R3645
914.4 (36)	VE**-36R845	VE**-36R1245	VE**-36R2445	VE**-36R3645

Incluye 2 conectores y tornillería • *Two connectors and hardware included*
 Todas las dimensiones en mm (pulg) • *All dimensions are in mm (in)*

Curva vertical interior a 45° y 90° • 45° & 90° Inside vertical bend

VIZP-12R890-1 A

- Material y acabado (ver pag 69) • Material & finishes (see page 69)
- Sufijo p/peralte (ver pag 69) • Rail height suffix (see page 69)
- Ángulo de la curva • Angle bend
- Radio • Radius
- Ancho • Width
- Tipo de fondo y perfil (ver pag 69) • Rail & trough type (see page 69)
- Curva vertical interior • Inside vertical bend

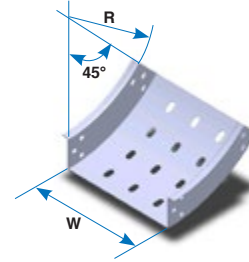
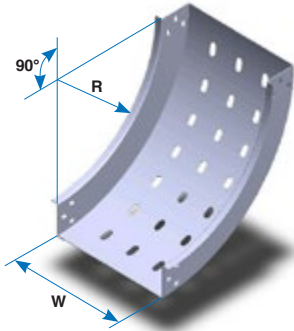

Números de catálogo para curva a 90° • 90° Bend's Catalog number

Ancho W Width W	Radio Radius			
	203.2 (8)	304.8 (12)	609.6 (24)	914.4 (36)
101.6 (4)	VI**-04R890	VI**-04R1290	VI**-04R2490	VI**-04R3690
152.4 (6)	VI**-06R890	VI**-06R1290	VI**-06R2490	VI**-06R3690
228.9 (9)	VI**-09R890	VI**-09R1290	VI**-09R2490	VI**-09R3690
304.8 (12)	VI**-12R890	VI**-12R1290	VI**-12R2490	VI**-12R3690
406.4 (16)	VI**-16R890	VI**-16R1290	VI**-16R2490	VI**-16R3690
457.2 (18)	VI**-18R890	VI**-18R1290	VI**-18R2490	VI**-18R3690
508.0 (20)	VI**-20R890	VI**-20R1290	VI**-20R2490	VI**-20R3690
609.6 (24)	VI**-24R890	VI**-24R1290	VI**-24R2490	VI**-24R3690
762.0 (30)	VI**-30R890	VI**-30R1290	VI**-30R2490	VI**-30R3690
914.4 (36)	VI**-36R890	VI**-36R1290	VI**-36R2490	VI**-36R3690

Números de catálogo para curva a 45° • 45° Bend's Catalog number

Ancho W Width W	Radio Radius			
	203.2 (8)	304.8 (12)	609.6 (24)	914.4 (36)
101.6 (4)	VI**-04R845	VI**-04R1245	VI**-04R2445	VI**-04R3645
152.4 (6)	VI**-06R845	VI**-06R1245	VI**-06R2445	VI**-06R3645
228.9 (9)	VI**-09R845	VI**-09R1245	VI**-09R2445	VI**-09R3645
304.8 (12)	VI**-12R845	VI**-12R1245	VI**-12R2445	VI**-12R3645
406.4 (16)	VI**-16R845	VI**-16R1245	VI**-16R2445	VI**-16R3645
457.2 (18)	VI**-18R845	VI**-18R1245	VI**-18R2445	VI**-18R3645
508.0 (20)	VI**-20R845	VI**-20R1245	VI**-20R2445	VI**-20R3645
609.6 (24)	VI**-24R845	VI**-24R1245	VI**-24R2445	VI**-24R3645
762.0 (30)	VI**-30R845	VI**-30R1245	VI**-30R2445	VI**-30R3645
914.4 (36)	VI**-36R845	VI**-36R1245	VI**-36R2445	VI**-36R3645

Incluye 2 conectores y tornillería • Two connectors and hardware included
 Todas las dimensiones en mm (pulg) • All dimensions are in mm (in)

“T” Horizontal • Horizontal tee

THZL-12R8-1 A

Material y acabado (ver pag 69) • *Material & finishes (see page 69)*
 Sufijo p/peralte (ver pag 69) • *Rail height suffix (see page 69)*
 Radio • *Radius*
 Ancho • *Width*
 Tipo de fondo y perfil (ver pag 69) • *Rail & trough type (see page 69)*
 “T” horizontal • *Horizontal “T”*

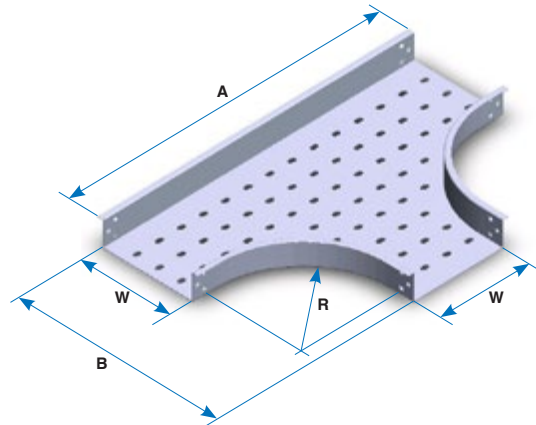

Ancho W Width W	Radio 203.2 Solo radial Radius (8) Radial only			Radio 304.8 Radius (12)		
	No. de catálogo Catalog number	A	B	No. de catálogo Catalog number	A	B
101.6 (4)	TH**-04R8	731 (28.78)	416 (16.39)	TH**-04R12	864 (34)	518 (20.39)
152.4 (6)	TH**-06R8	782 (30.78)	467 (18.39)	TH**-06R12	914 (36)	569 (22.39)
228.9 (9)	TH**-09R8	585 (23.03)	543 (21.39)	TH**-09R12	991 (39)	645 (25.39)
304.8 (12)	TH**-12R8	934 (36.78)	619 (24.39)	TH**-12R12	1137 (44.78)	721 (28.39)
406.4 (16)	TH**-16R8	1036 (40.78)	721 (28.39)	TH**-16R12	1239 (48.78)	823 (32.39)
457.2 (18)	TH**-18R8	1086 (42.78)	772 (30.39)	TH**-18R12	1290 (50.78)	873 (34.39)
508.0 (20)	TH**-20R8	1137 (44.78)	823 (32.39)	TH**-20R12	1341 (52.78)	924 (36.39)
609.6 (24)	TH**-24R8	1239 (48.78)	924 (36.39)	TH**-24R12	1442 (56.78)	1026 (40.39)
762.0 (30)	TH**-30R8	1391 (54.78)	1077 (42.39)	TH**-30R12	1595 (62.78)	1178 (46.39)
914.4 (36)	TH**-36R8	1543 (60.78)	1229 (48.39)	TH**-36R12	1747 (68.78)	1331 (52.39)

Ancho W Width W	Radio 609.6 Radius (24)			Radio 914.4 Radius (36)		
	No. de catálogo Catalog number	A	B	No. de catálogo Catalog number	A	B
101.6 (4)	TH**-04R24	1544 (60.78)	823 (32.39)	TH**-04R36	2153 (84.78)	1127 (44.39)
152.4 (6)	TH**-06R24	1595 (62.78)	873 (34.39)	TH**-06R36	2204 (86.78)	1178 (46.39)
228.9 (9)	TH**-09R24	1671 (65.78)	950 (37.39)	TH**-09R36	2280 (89.78)	1254 (49.39)
304.8 (12)	TH**-12R24	1747 (68.78)	1030 (40.39)	TH**-12R36	2357 (92.78)	1331 (52.39)
406.4 (16)	TH**-16R24	1849 (72.78)	1127 (44.39)	TH**-16R36	2458 (96.78)	1432 (56.39)
457.2 (18)	TH**-18R24	1899 (74.78)	1178 (46.39)	TH**-18R36	2509 (98.78)	1483 (58.39)
508.0 (20)	TH**-20R24	1950 (76.78)	1229 (48.39)	TH**-20R36	2560 (100.78)	1534 (60.39)
609.6 (24)	TH**-24R24	2052 (80.78)	1331 (52.39)	TH**-24R36	2661 (104.78)	1635 (64.39)
762.0 (30)	TH**-30R24	2204 (86.78)	1483 (58.39)	TH**-30R36	2814 (110.78)	1788 (70.39)
914.4 (36)	TH**-36R24	2357 (92.78)	1635 (64.39)	TH**-36R36	2966 (116.78)	1940 (76.39)

Incluye 2 conectores y tornillería • *Two connectors and hardware included*
 Todas las dimensiones en mm (pulg) • *All dimensions are in mm (in)*

“X” Horizontal • Horizontal cross

XHZP-12R8-1 A

- Material y acabado (ver pag 69) • *Material & finishes (see page 69)*
- Sufijo p/peralte (ver pag 69) • *Rail height suffix (see page 69)*
- Radio • *Radius*
- Ancho • *Width*
- Tipo de fondo y perfil (ver pag 69) • *Rail & trough type (see page 69)*
- “X” Horizontal • *Horizontal cross*

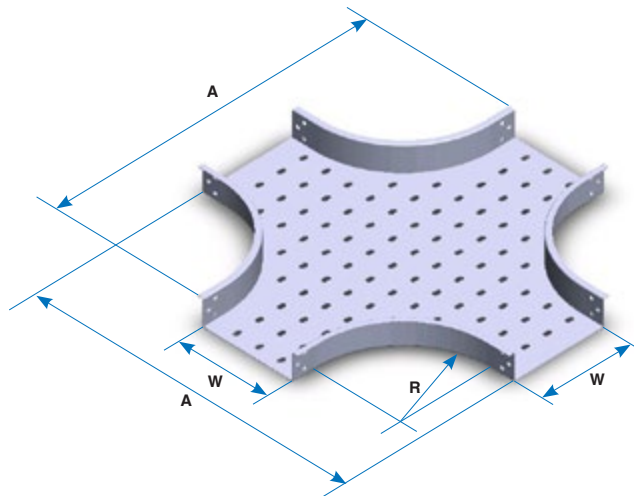

Ancho W Width W	Radio 203.2 Solo radial <i>Radius (8) Radial only</i>		Radio 304.8 <i>Radius (12)</i>	
	No. de catálogo <i>Catalog number</i>	A	No. de catálogo <i>Catalog number</i>	A
101.6 (4)	XH**-04R8	731 (28.78)	XH**-04R12	864 (34)
152.4 (6)	XH**-06R8	782 (30.78)	XH**-06R12	914 (36)
228.9 (9)	XH**-09R8	585 (23.03)	XH**-09R12	991 (39)
304.8 (12)	XH**-12R8	934 (36.78)	XH**-12R12	1137 (44.78)
406.4 (16)	XH**-16R8	1036 (40.78)	XH**-16R12	1239 (48.78)
457.2 (18)	XH**-18R8	1086 (42.78)	XH**-18R12	1290 (50.78)
508.0 (20)	XH**-20R8	1137 (44.78)	XH**-20R12	1341 (52.78)
609.6 (24)	XH**-24R8	1239 (48.78)	XH**-24R12	1442 (56.78)
762.0 (30)	XH**-30R8	1391 (54.78)	XH**-30R12	1595 (62.78)
914.4 (36)	XH**-36R8	1543 (60.78)	XH**-36R12	1747 (68.78)

Ancho W Width W	Radio 609.6 <i>Radius (24)</i>		Radio 914.4 <i>Radius (36)</i>	
	No. de catálogo <i>Catalog number</i>	A	No. de catálogo <i>Catalog number</i>	A
101.6 (4)	XH**-04R24	1544 (60.78)	XH**-04R36	2153 (84.78)
152.4 (6)	XH**-06R24	1595 (62.78)	XH**-06R36	2204 (86.78)
228.9 (9)	XH**-09R24	1671 (65.78)	XH**-09R36	2280 (89.78)
304.8 (12)	XH**-12R24	1747 (68.78)	XH**-12R36	2357 (92.78)
406.4 (16)	XH**-16R24	1849 (72.78)	XH**-16R36	2458 (96.78)
457.2 (18)	XH**-18R24	1899 (74.78)	XH**-18R36	2509 (98.78)
508.0 (20)	XH**-20R24	1950 (76.78)	XH**-20R36	2560 (100.78)
609.6 (24)	XH**-24R24	2052 (80.78)	XH**-24R36	2661 (104.78)
762.0 (30)	XH**-30R24	2204 (86.78)	XH**-30R36	2814 (110.78)
914.4 (36)	XH**-36R24	2357 (92.78)	XH**-36R36	2966 (116.78)

Incluye 2 conectores y tornillería • *Two connectors and hardware included*
 Todas las dimensiones en mm (pulg) • *All dimensions are in mm (in)*

“T” Vertical • Vertical tee

TVZP-12R8-1 A

Material y acabado (ver pag 69) • Material & finishes (see page 69)
 Sufijo p/peralte (ver pag 69) • Rail height suffix (see page 69)
 Radio • Radius
 Ancho • Width
 Tipo de fondo y perfil (ver pag 69) • Rail & trough type (see page 69)
 “T” vertical • Vertical “T”

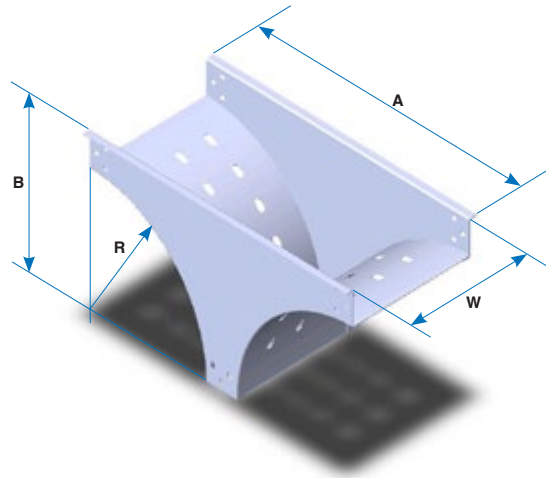

Ancho W Width W	Radio Radius			
	203.2 (8)	304.8 (12)	609.6 (24)	914.4 (36)
101.6 (4)	TV**-04R8	TV**-04R12	TV**-04R24	TV**-04R36
152.4 (6)	TV**-06R8	TV**-06R12	TV**-06R24	TV**-06R36
228.9 (9)	TV**-09R8	TV**-09R12	TV**-09R24	TV**-09R36
304.8 (12)	TV**-12R8	TV**-12R12	TV**-12R24	TV**-12R36
406.4 (16)	TV**-16R8	TV**-16R12	TV**-16R24	TV**-16R36
457.2 (18)	TV**-18R8	TV**-18R12	TV**-18R24	TV**-18R36
508.0 (20)	TV**-20R8	TV**-20R12	TV**-20R24	TV**-20R36
609.6 (24)	TV**-24R8	TV**-24R12	TV**-24R24	TV**-24R36
762.0 (30)	TV**-30R8	TV**-30R12	TV**-30R24	TV**-30R36
914.4 (36)	TV**-36R8	TV**-36R12	TV**-36R24	TV**-36R36

Sufijo p/peralte Height rail suffix	Radio • Radius							
	203.2 (8)		304.8 (12)		609.6 (24)		914.4 (36)	
	A	B	A	B	A	B	A	B
1	489 (19.25)	286 (11.25)	692 (27.25)	387 (15.25)	1302 (51.25)	692 (27.25)	1911 (75.25)	997 (39.25)
2	508 (20)	305 (12)	711 (28)	406 (16)	1321 (52)	711 (28)	1930 (76)	1016 (40)
3	521 (20.5)	318 (12.5)	724 (28.5)	419 (16.5)	1334 (52.5)	724 (28.5)	1943 (76.5)	1029 (40.5)
5	533 (21)	330 (13)	737 (29)	432 (17)	1346 (53)	737 (29)	1956 (77)	1041 (41)
6	559 (22)	356 (14)	762 (30)	457 (18)	1372 (54)	762 (30)	1981 (78)	1067 (42)

Incluye 2 conectores y tornillería • Two connectors and hardware included
 Todas las dimensiones en mm (pulg) • All dimensions are in mm (in)

Curva horizontal ajustable • Horizontal adjustable bend

CAZP-12-1 A

- Material y acabado (ver pag 69) • *Material & finishes (see page 69)*
- Sufijo p/peralte (ver pag 69) • *Rail height suffix (see page 69)*
- Ancho • *Width*
- Tipo de fondo y perfil (ver pag 69) • *Rail & trough type (see page 69)*
- Curva horizontal ajustable • *Horizontal adjustable bend*

Ancho W Width W	No. de catálogo Catalog number
101.6 (4)	CA**-04
152.4 (6)	CA**-06
228.9 (9)	CA**-09
304.8 (12)	CA**-12
406.4 (16)	CA**-16
457.2 (18)	CA**-18
508.0 (20)	CA**-20
609.6 (24)	CA**-24
762.0 (30)	CA**-30
914.4 (36)	CA**-36

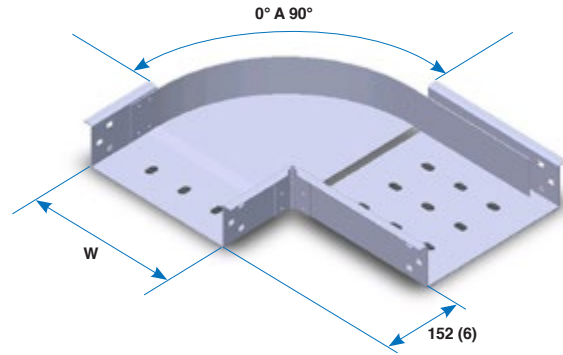

Incluye 2 conectores y tornillería • *Two connectors and hardware included*
 No incluye cintas conductoras • *Bonding jumpers not included*
 Todas las dimensiones en mm (pulg) • *All dimensions are in mm (in)*

Derivación horizontal a 45° • 45° Horizontal wye branch

DY * ZP-12-1 A

- Material y acabado (ver pag 69) • *Material & finishes (see page 69)*
- Sufijo p/peralte (ver pag 69) • *Rail height suffix (see page 69)*
- Ancho • *Width*
- Tipo de fondo y perfil (ver pag 69) • *Rail & trough type (see page 69)*
- Colocar "D" para derecha o "I" izquierda • *Add "D" for right or "I" for left*
- Derivación horizontal a 45° • *45° Horizontal wye branch*

Ancho W Width W	No. de catálogo Catalog number	A
101.6 (4)	DY**-04	463 (18.2)
152.4 (6)	DY**-06	534 (21)
228.9 (9)	DY**-09	642 (25.3)
304.8 (12)	DY**-12	750 (29.5)
406.4 (16)	DY**-16	894 (35.2)
457.2 (18)	DY**-18	966 (38)
508.0 (20)	DY**-20	1037 (40.8)
609.6 (24)	DY**-24	1181 (46.5)
762.0 (30)	DY**-30	1396 (55)
914.4 (36)	DY**-36	1612 (63.5)

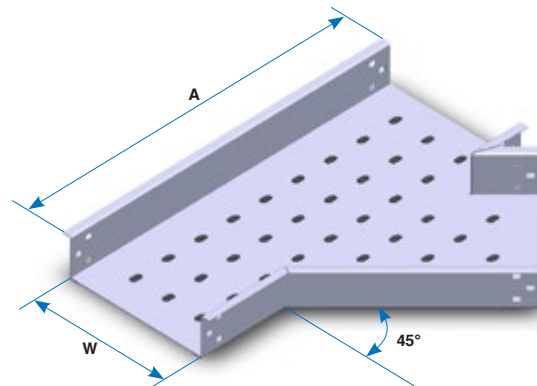

Incluye 2 conectores y tornillería • *Two connectors and hardware included*
 Todas las dimensiones en mm (pulg) • *All dimensions are in mm (in)*

Reducciones • Reducers

RL ZP-1209-1 A

- Material y acabado • *Material & finishes*
- Sufijo p/peralte (ver pag 69) • *Rail height suffix (see page 69)*
- Ancho menor • *Smaller width*
- Ancho mayor • *Larger width*
- Perfil tipo (ver pag 69) • *Rail type (see page 69)*
- Reducción • *Reducer*
- RL = Recta • *Straight*
- RLD = Derecha • *Right*
- RLI = Izquierda • *Left*

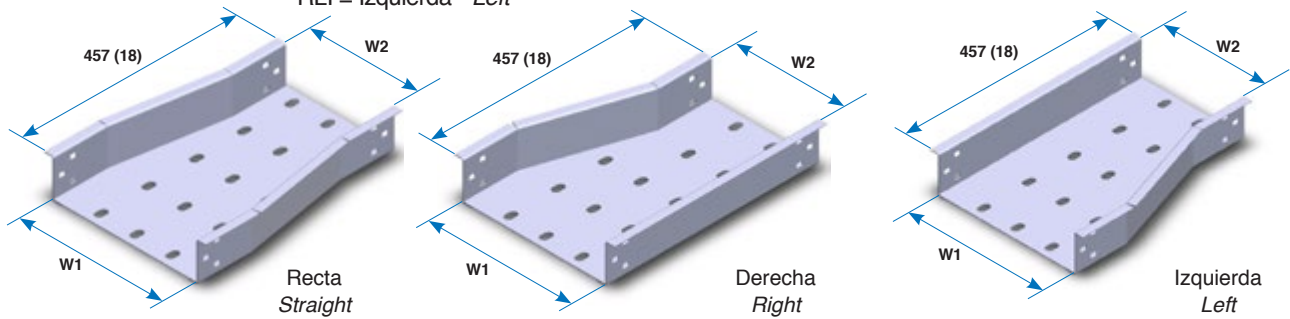

Nº de catálogo reducciones rectas • *Straight reducer catalog number*

Ancho W1 Width W1	Ancho menor W2 Smaller width W2								
	101.6 (4)	152.4 (6)	228.9 (9)	304.8 (12)	406.4 (16)	457.2 (18)	508.0 (20)	609.6 (24)	762.0 (30)
152.4 (6)	RL**-0604								
228.9 (9)	RL**-0904	RL**-0906							
304.8 (12)	RL**-1204	RL**-1206	RL**-1209						
406.4 (16)	RL**-1604	RL**-1606	RL**-1609	RL**-1612					
457.2 (18)	RL**-1804	RL**-1806	RL**-1809	RL**-1812	RL**-1816				
508.0 (20)	RL**-2004	RL**-2006	RL**-2009	RL**-2012	RL**-2016	RL**-2018			
609.6 (24)	RL**-2404	RL**-2406	RL**-2409	RL**-2412	RL**-2416	RL**-2418	RL**-2420		
762.0 (30)	RL**-3004	RL**-3006	RL**-3009	RL**-3012	RL**-3016	RL**-3018	RL**-3020	RL**-3024	
914.4 (36)	RL**-3604	RL**-3606	RL**-3609	RL**-3612	RL**-3616	RL**-3618	RL**-3620	RL**-3624	RL**-3630

Nº de catálogo reducciones derechas • *Right reducer catalog number*

Ancho W1 Width W1	Ancho menor W2 Smaller width W2								
	101.6 (4)	152.4 (6)	228.9 (9)	304.8 (12)	406.4 (16)	457.2 (18)	508.0 (20)	609.6 (24)	762.0 (30)
152.4 (6)	RLD**-0604								
228.9 (9)	RLD**-0904	RLD**-0906							
304.8 (12)	RLD**-1204	RLD**-1206	RLD**-1209						
406.4 (16)	RLD**-1604	RLD**-1606	RLD**-1609	RLD**-1612					
457.2 (18)	RLD**-1804	RLD**-1806	RLD**-1809	RLD**-1812	RLD**-1816				
508.0 (20)	RLD**-2004	RLD**-2006	RLD**-2009	RLD**-2012	RLD**-2016	RLD**-2018			
609.6 (24)	RLD**-2404	RLD**-2406	RLD**-2409	RLD**-2412	RLD**-2416	RLD**-2418	RLD**-2420		
762.0 (30)	RLD**-3004	RLD**-3006	RLD**-3009	RLD**-3012	RLD**-3016	RLD**-3018	RLD**-3020	RLD**-3024	
914.4 (36)	RLD**-3604	RLD**-3606	RLD**-3609	RLD**-3612	RLD**-3616	RLD**-3618	RLD**-3620	RLD**-3624	RLD**-3630

Nº de catálogo reducciones izquierdas • *Left reducer catalog number*

Ancho W1 Width W1	Ancho menor W2 Smaller width W2								
	101.6 (4)	152.4 (6)	228.9 (9)	304.8 (12)	406.4 (16)	457.2 (18)	508.0 (20)	609.6 (24)	762.0 (30)
152.4 (6)	RLI**-0604								
228.9 (9)	RLI**-0904	RLI**-0906							
304.8 (12)	RLI**-1204	RLI**-1206	RLI**-1209						
406.4 (16)	RLI**-1604	RLI**-1606	RLI**-1609	RLI**-1612					
457.2 (18)	RLI**-1804	RLI**-1806	RLI**-1809	RLI**-1812	RLI**-1816				
508.0 (20)	RLI**-2004	RLI**-2006	RLI**-2009	RLI**-2012	RLI**-2016	RLI**-2018			
609.6 (24)	RLI**-2404	RLI**-2406	RLI**-2409	RLI**-2412	RLI**-2416	RLI**-2418	RLI**-2420		
762.0 (30)	RLI**-3004	RLI**-3006	RLI**-3009	RLI**-3012	RLI**-3016	RLI**-3018	RLI**-3020	RLI**-3024	
914.4 (36)	RLI**-3604	RLI**-3606	RLI**-3609	RLI**-3612	RLI**-3616	RLI**-3618	RLI**-3620	RLI**-3624	RLI**-3630

Todas las dimensiones en mm (pulg) • *All dimensions are in mm (in)*

Incluye 2 conectores y tornillería • *Two connectors and hardware included*

Sección 4.3 Accesorios de ensamble para charolas tipo escalera y fondo sólido

Section 4.3 Assembly fittings for ladder and solid trough type cable tray systems.

Conector tipo "Z" • "Z" Form splice plate

AZ-4.5 1 A

- Material y acabado (ver pag 58) • *Material & finishes (see page 58)*
- Sufijo p/peralte (ver pag 59) • *Rail height suffix (see page 59)*
- Largo en pulg. • *Length in inches*
- Conector tipo z • *Z form connector*

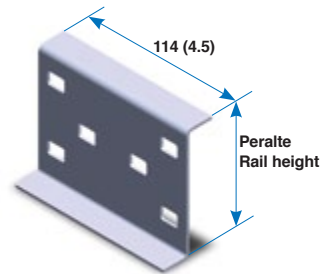
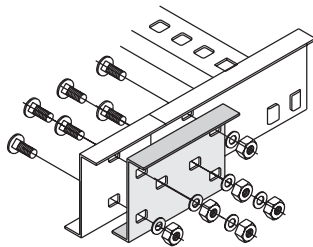

Aplicable solo para productos perfil tipo Z • *Use only with products Z rail side form*
Tornillería incluida • *Hardware included*

Todas las dimensiones en mm (pulg) • *All dimensions are in mm (in)*

Conector recto • Straight splice plate

AR-4.5 1 A

- Material y acabado (ver pag 58) • *Material & finishes (see page 58)*
- Sufijo p/peralte (ver pag 59) • *Rail height suffix (see page 59)*
- Largo en pulg. • *Length in inches*
- Conector recto • *Straight connector*

Tornillería incluida • *Hardware included*

Todas las dimensiones en mm (pulg) • *All dimensions are in mm (in)*

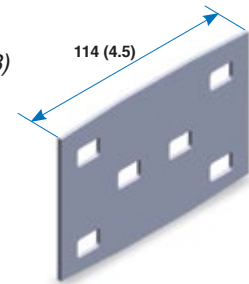

Conector tipo "L" • "L" Form splice plate

AL-4.5 1 A

- Material y acabado (ver pag 58) • *Material & finishes (see page 58)*
- Sufijo p/peralte (ver pag 59) • *Rail height suffix (see page 59)*
- Largo en pulg. • *Length in inches*
- Conector tipo L • *L form connector*

Tornillería incluida • *Hardware included*

Todas las dimensiones en mm (pulg) • *All dimensions are in mm (in)*

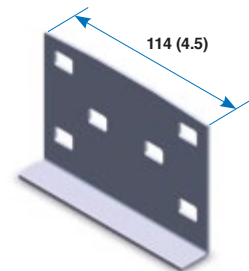

Conector de expansión • Expansion connector

AE-1 A

- Material y acabado (ver pag 58) • *Material & finishes (see page 58)*
- Sufijo p/peralte (ver pag 59) • *Rail height suffix (see page 59)*
- Conector de expansión • *Expansion connector*

Tornillería incluida • *Hardware included*

Todas las dimensiones en mm (pulg) • *All dimensions are in mm (in)*

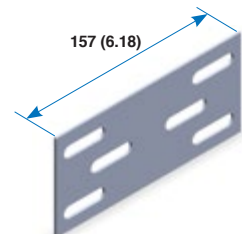

Elevador ajustable • Vertical adjustable connector

EA-1 A

Material y acabado (ver pag 58) • *Material & finishes (see page 58)*
 Sufijo p/peralte (ver pag 59) • *Rail height suffix (see page 59)*
 Elevador ajustable • *Vertical adjustable connector*

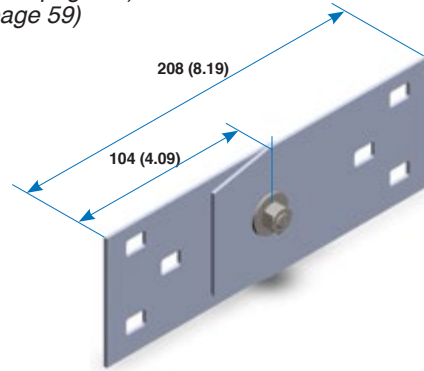

No incluye cintas conductoras • *Bonding jumpers not included*
 Tornillería incluida • *Hardware included*

Conector horizontal ajustable • Horizontal adjustable connector

AH-1 A

Material y acabado (ver pag 58) • *Material & finishes (see page 58)*
 Sufijo p/peralte (ver pag 59) • *Rail height suffix (see page 59)*
 Conector horizontal ajustable • *Horizontal adjustable connector*

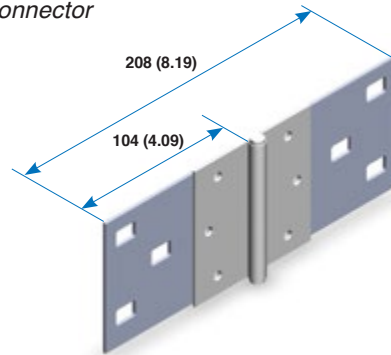

No incluye cintas conductoras • *Bonding jumpers not included*

Conector reductor • Reducer connector

ARR - 3 - 1 A

Material y acabado (ver pag 58) • *Material & finishes (see page 58)*
 Sufijo p/peralte (ver pag 59) • *Rail height suffix (see page 59)*
 Diferencia de anchos ver tabla • *Width difference see table*
 Conector reductor • *Reducer connector*

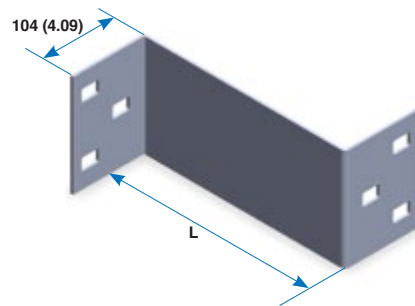

No. de catálogo <i>Catalog number</i>	L mm (pulg)
ARR-1	76.2 (3")
ARR-2	152.4(6")
ARR-3	228.6(9")
ARR-4	304.8(12")
ARR-5	381.0(15")
ARR-6	457.2(18")
ARR-7	609.6(24")
ARR-8	762.0(30")

Medidas de reducción de línea.
 La reducción se puede fabricar en cualquier medida solicitada
 Tornillería incluida • *Hardware included*

Todas las dimensiones en mm (pulg) • *All dimensions are in mm (in)*

PTR-09-1 A

Tapa terminal • Blind end

- Material y acabado (ver pag 58) • *Material & finishes (see page 58)*
- Sufijo p/peralte (ver pag 59) • *Rail height suffix (see page 59)*
- Ancho de la charola • *Cable tray width*
- Tapa terminal • *Blind end*

Ancho de Charola Tray Width	W1
101.6 (4)	106(4.19)
152.4 (6)	157 (6.19)
228.9 (9)	233 (6.19)
304.8 (12)	309 (12.19)
406.4 (16)	411 (16.19)
457.2 (18)	462 (18.19)
508.0 (20)	513 (20.19)
609.6 (24)	614 (24.19)
762.0 (30)	767 (30.19)
914.4 (36)	919 (36.19)

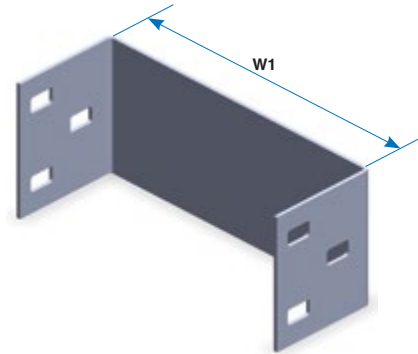

Tornillería incluida • *Hardware included*

ACC-09-1 A

Conector de charola a caja • Frame type box connector

- Material y acabado (ver pag 58) • *Material & finishes (see page 58)*
- Sufijo p/peralte (ver pag 59) • *Rail height suffix (see page 59)*
- Ancho de la charola • *Cable tray width*
- Conector charola a caja • *Frame type box connector*

Ancho de Charola Tray Width	W1
101.6 (4)	106(4.19)
152.4 (6)	157 (6.19)
228.9 (9)	233 (6.19)
304.8 (12)	309 (12.19)
406.4 (16)	411 (16.19)
457.2 (18)	462 (18.19)
508.0 (20)	513 (20.19)
609.6 (24)	614 (24.19)
762.0 (30)	767 (30.19)
914.4 (36)	919 (36.19)

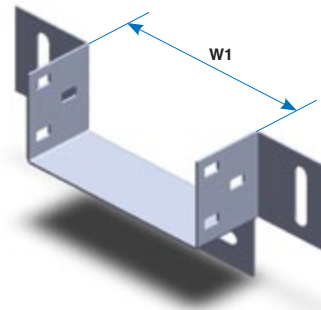

Tornillería incluida • *Hardware included*

BC-509-1 A

Bajada para cable • Drop-out

- Material y acabado (ver pag 58) • *Material & finishes (see page 58)*
- Sufijo p/peralte (ver pag 59) • *Rail height suffix (see page 59)*
- Ancho de la charola • *Cable tray width*
- Radio de la bajada • *Drop-out radius*
- Bajada para cables • *Drop-out*

Ancho de Charola Tray Width	Radio 50.8 Radius (2)	Radio 127 Radius (5)
101.6 (4)	BC-204	BC-504
152.4 (6)	BC-206	BC-506
228.9 (9)	BC-209	BC-509
304.8 (12)	BC-212	BC-512
406.4 (16)	BC-216	BC-516
457.2 (18)	BC-218	BC-518
508.0 (20)	BC-220	BC-520
609.6 (24)	BC-224	BC-524
762.0 (30)	BC-230	BC-530
914.4 (36)	BC-236	BC-536

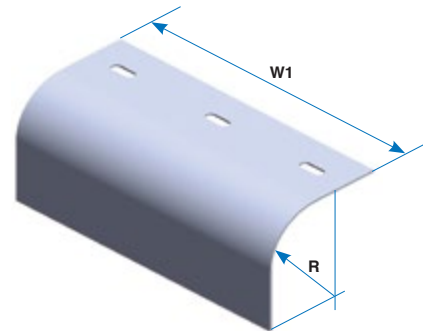

Tornillería no incluida • *Hardware not included*

Todas las dimensiones en mm (pulg) • *All dimensions are in mm (in)*

Barreras separadoras tramo recto • Straight divider strip

BSCH-1 A 3.05m

Longitud de la charola en metros (3.05m y 3.66m) • *Cable tray length in meters (3.05m and 3.66m)*
 Material y acabado (ver pag 58) • *Material & finishes (see page 58)*
 Sufijo p/peralte (ver pag 58) • *Rail height suffix (see page 58)*
 Barrera separadora para tramo recto • *Straight divider strip*

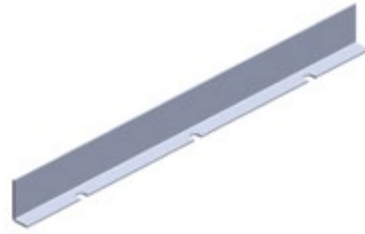

Incluye 5 clemas Clamp-112 con tornillería • *Five hold down Clamp-112 and hardware included*

Barreras separadoras accesorios horizontales • Horizontal fittings divider strip

BSH-72-1 A

Material y acabado (ver pag 58) • *Material & finishes (see page 58)*
 Sufijo p/peralte (ver pag 58) • *Rail height suffix (see page 58)*
 Longitud de la barrera en pulgadas (48" y 72") • *Divider strip length in inches (48" and 72")*
 Barrera separadora para curva horizontal • *Horizontal fitting divider strip*



Incluye 3 clemas Clamp-112 con tornillería • *Three hold down Clamp-112 and hardware included*

Barreras separadoras accesorios verticales • Vertical fittings divider strip

BSVEC-04R08901 A

No de catálogo de la curva a la que se colocara la barrera.
Catalog number of the vertical fitting
 Barrera separadora para curva vertical • *Vertical fitting divider strip*



Incluye clemas Clamp-112 con tornillería • *Hold down Clamp-112 and hardware included*

Cintas conductoras • Bonding jumpers

Para su selección y aplicación consulte NOM-001-SEDE-2012 artículos 318-6A y 318-7, además de NEMA VE-2
For application and selection, see NEC CODE 318-6A & 318-7, also NEMA VE-2

No de catálogo <i>Catalog number</i>	Capacidad <i>Capacity</i>
CC-99NI	600 AMP. MAX.
CC-9940	1600 AMP. MAX



Todas las dimensiones en mm (pulg) • *All dimensions are in mm (in)*

Tapas para tramo recto • Straight covers

TRCV-CHCP-12-1A

No de catálogo de la pieza a cubrir • *Covered product catalog number*
 Tipo de tapa • *Cover type*



Tapa recta tipo "TR"
Flat cover "TR" type



Tapa con ceja tipo "TRC"
Flanged cover "TRC" type



Tapa a dos aguas tipo "TA"
Peaked cover "TA" type

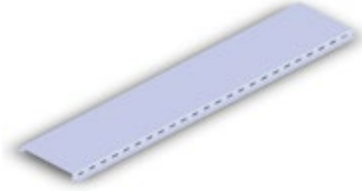

Tapa sombrero tipo "TSS"
Domed cover "TSS" type

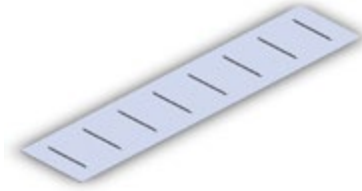

Tapa recta con ventilación tipo "TRV"
Flat vented cover "TRV" type

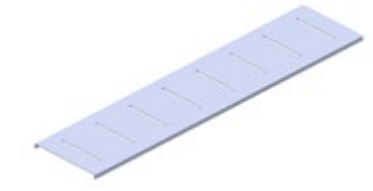

Tapa con ceja con ventilación tipo "TRCV"
Flanged and vented cover "TRCV" type

Las tapas se surten en juegos de 3 tapas de 1219 mm (4 ft) e incluyen 12 clips de sujeción

Covers are supplied in sets of 3 covers of 1219 mm (4 ft) 12 cover clamps are included

Para otras longitudes consulte nuestro departamento de ingeniería

For other lengths or designs please consult our technical department

Las tapas para accesorios solo se fabrican en tipo recto e incluyen clips necesarios.

Only flat type is supplied for fitting covers and cover clamps needed are included

Las tapas para charola tipo fondo sólido se surten en juegos de 2 tapas de 1525 mm (5 ft) e incluyen 8 clips
Solid trough type cable tray covers are supplied in sets of 2 covers of 1525 mm (5 ft) 8 cover clamps are included.

Clips de sujeción para tapas • Cover clamps

CST-14-GI

Material y acabado (ver pag 58) • *Material & finishes (see page 58)*
 Clip normal • *Standard clamp*

CSTSC-14-1GI

Material y acabado (ver pag 58) • *Material & finishes (see page 58)*
 Sufijo p/peralte (ver pag 58) • *Rail height suffix (see page 58)*
 Clip largo • *Large clamp*

Para charolas perfiles tipo "Z", "C" afuera, e "I"
For products with rail type "Z", "C" flanged out, & "I"

Para charolas perfiles tipo "C"
For products with rail type "C"

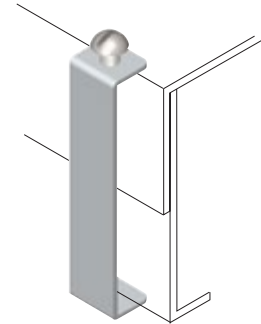
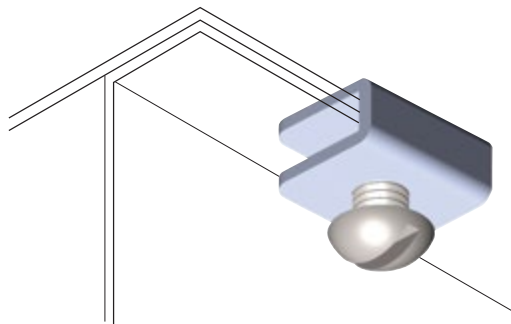

Todas las dimensiones en mm (pulg) • *All dimensions are in mm (in)*

Sección 4.4 Accesorios de montaje

Section 4.4 Supports and brackets

Ménsula para montaje en pared • Wall cantilever bracket

MPPI-09-GI

Material y acabado • *Material & finishes*
 Ancho de la charola • *Cable tray width*
 Colocar esta letra para charolas con perfil tipo "C" hacia fuera, e "I"
Use this letter for "C" flange out & "I" rail trays
 Ménsula para pared • *Wall supported bracket*

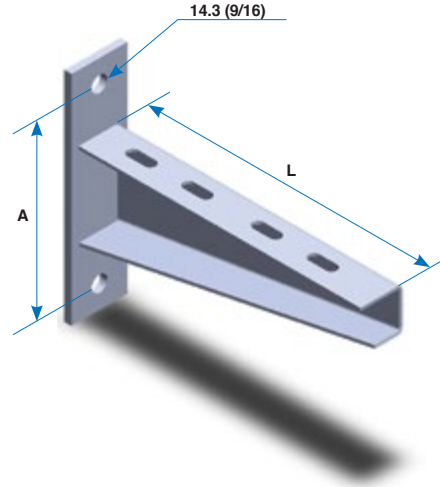
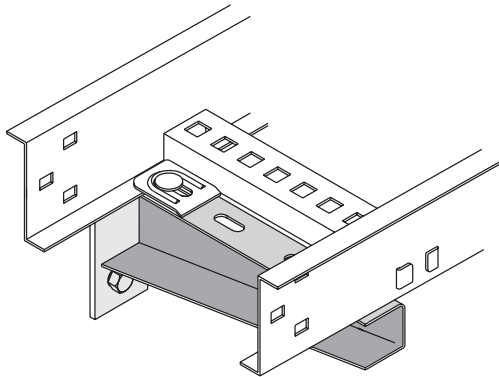

Ancho de charola Tray width	A	Para perfil tipo Z, C, I (ligero) (ver pag 58) For Z, C, I rail type (see page 58)		Para perfil tipo "C" hacia afuera, e "I" (pesado) (ver pag 58) For "C" flanged out & "I" rail type (see page 58)		Carga soportada Load capacity
		No de catálogo Catalog number	L	No de catálogo Catalog number	L	
101.6 (4)	120 (4.75)	MPP-04	127 (5)	MPPI-04	152 (6)	705 kg (1550 lb)
152.4 (6)		MPP-06	178 (7)	MPPI-06	203 (8)	665 kg (1460 lb)
228.9 (9)		MPP-09	254 (10)	MPPI-09	279 (11)	645 kg (1420 lb)
304.8 (12)		MPP-12	330 (13)	MPPI-12	356 (14)	550 kg (1215 lb)
406.4 (16)	158 (6.22)	MPP-16	432 (17)	MPPI-16	457 (18)	505 kg (1115 lb)
457.2 (18)		MPP-18	483 (19)	MPPI-18	508 (20)	450 kg (990 lb)
508.0 (20)		MPP-20	533 (21)	MPPI-20	559 (22)	385 kg (850 lb)
609.6 (24)		MPP-24	635 (25)	MPPI-24	660 (26)	325 kg (717 lb)
762.0 (30)		MPP-30	787 (31)	MPPI-30	813 (32)	275 kg (607 lb)
914.4 (36)		MPP-36	940 (37)	MPPI-36	965 (38)	225 kg (496 lb)

No incluye tornillería ni sistemas de fijación. • *Hardware, clamps or anchoring system are not included*

La carga soportada muestra la capacidad de la ménsula, CROSS LINE no se hace responsable de fallas atribuibles a los sistemas de anclaje o el sustrato de apoyo.

The load shown indicates bracket's load capacity. CROSS LINE is not responsible for failures caused by the anchoring system or wall materials.

Las cargas soportadas están basadas en un factor de seguridad de 2.5.

Load capacities are based in a 2.5 safety factor.

Materiales y acabados:

GI: Acero al carbón galvanizado por inmersión en caliente

GE: Acero al carbón galvanizado electrolítico

T: Acero al carbón tropicalizado

PVC: Acero al carbón recubierto con PVC

AI: Acero inoxidable

Para materiales y acabados no indicados consulte nuestro departamento de ingeniería

Todas las dimensiones en mm (pulg)

Materials & finishes:

GI: Hot dip galvanized steel

GE: Electro galvanized steel

T: Chromium-zinc coated steel

PVC: PVC coated steel

AI: Stainless steel

For materials and finishes not shown please consult our technical department

All dimensions are in mm (in)

Ménsula para montaje en canal • Channel cantilever bracket

MCI-09-GI

- Material y acabado (ver pag 83) • *Material & finishes (see page 83)*
- Ancho de la charola • *Cable tray width*
- Colocar esta letra para charolas con perfil tipo "C" hacia fuera, e "I" • *Use this letter for "C" flange out & "I" rail trays*
- Ménsula para canal • *Channel cantilever bracket*

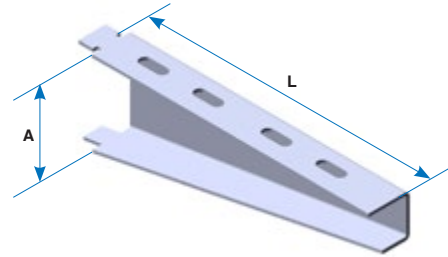
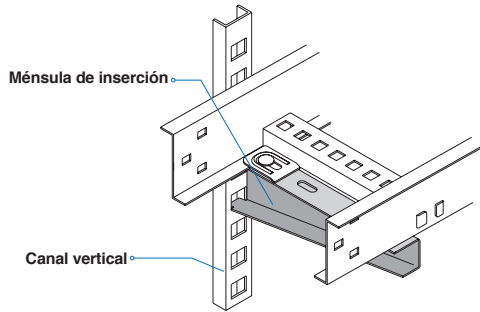

Ancho de charola Tray width	A	Para perfil tipo Z, C, I (ligero) (ver pag 58) For Z, C, I rail type (see page 58)		Para perfil tipo "C" hacia afuera, e "I" (pesado) (ver pag 58) For "C" flanged out & "I" rail type (see page 58)		Carga soportada Load capacity
		No de catálogo Catalog number	L	No de catálogo Catalog number	L	
101.6 (4)	79 (3.1)	MC-04	127 (5)	MCI-04	152 (6)	345 kg (762 lb)
152.4 (6)		MC-06	178 (7)	MCI-06	203 (8)	325 kg (717 lb)
228.9 (9)		MC-09	254 (10)	MCI-09	279 (11)	315 kg (695 lb)
304.8 (12)		MC-12	330 (13)	MCI-12	356 (14)	270 kg (596 lb)
406.4 (16)	158 (6.22)	MC-16	432 (17)	MCI-16	457 (18)	245 kg (540 lb)
457.2 (18)		MC-18	483 (19)	MCI-18	508 (20)	220 kg (485 lb)
508.0 (20)		MC-20	533 (21)	MCI-20	559 (22)	190 kg (420 lb)
609.6 (24)		MC-24	635 (25)	MCI-24	660 (26)	160 kg (353 lb)
762.0 (30)		MC-30	787 (31)	MCI-30	813 (32)	135 kg (298 lb)
914.4 (36)		MC-36	940 (37)	MCI-36	965 (38)	110 kg (243 lb)

La carga soportada muestra la capacidad de la ménsula, CROSS LINE no se hace responsable de fallas atribuibles a los sistemas de anclaje o el sustrato de apoyo.

The load shown indicates bracket's load capacity assembled with a vertical channel, CROSS LINE is not responsible for failures caused by the anchoring system or wall materials.

Las cargas soportadas están basadas en un factor de seguridad de 2.5.

Load capacities are based in a 2.5 safety factor.

Canal vertical • Vertical "C" channel

CVPP-120-GI

- Material y acabado (ver pag 83) • *Material & finishes (see page 83)*
- Longitud del canal en pulgadas • *Channel length in inches*
- Colocar esta letra en canales con altura de 19 mm (3/4) • *Use this letter for channels with 19 (3/4) height*
- Canal vertical • *Vertical "C" channel*

No de catálogo Catalog number	A
CVPP-120	19 (3/4)
CVP-120	31.8 (1 1/2)

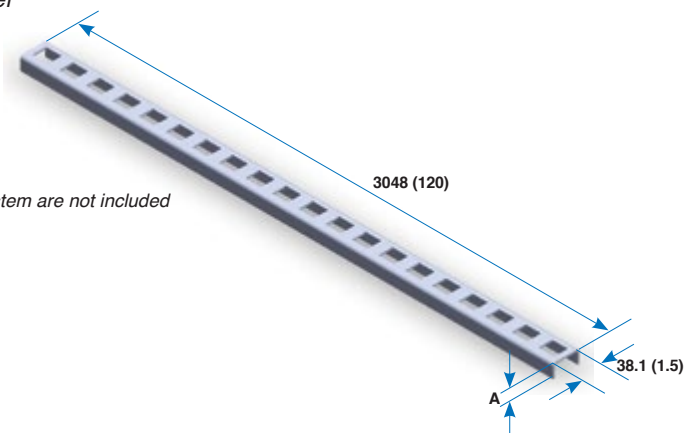

No incluye tornillería ni sistemas de fijación. • *Hardware, clamps or anchoring system are not included*
Todas las dimensiones en mm (pulg). • *All dimensions are in mm (in)*

Canal horizontal para trapecio • Channel cantilever bracket

CPPV-09-GI

Material y acabado (ver pag 83) • Material & finishes (see page 83)
 Ancho de la charola • Cable tray width
 Canal horizontal para trapecio • Horizontal channel for support

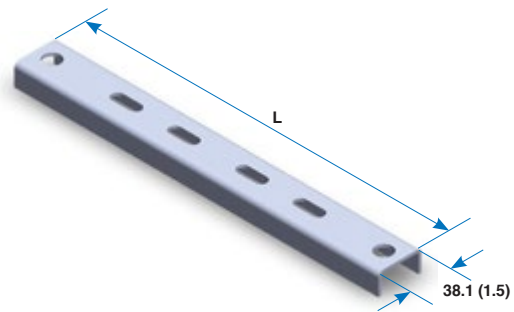
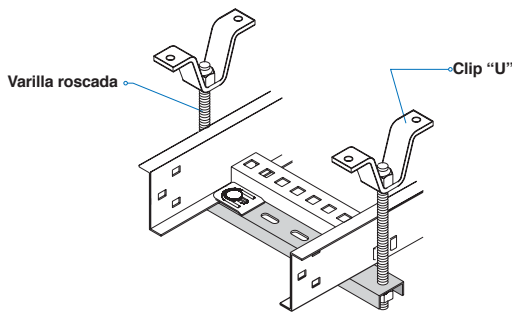

Números de catálogo • Catalog number

Canal poco profundo Minus deep horizontal channel	Canal horizontal profundo Deep horizontal channel	Ancho de charola Tray width	L
CPPV-04	CPV-04	101.6 (4)	195 (7.69)
CPPV-06	CPV-06	152.4 (6)	246 (9.69)
CPPV-09	CPV-09	228.9 (9)	322 (12.69)
CPPV-12	CPV-12	304.8 (12)	398 (15.69)
CPPV-16	CPV-16	406.4 (16)	500 (19.69)
CPPV-18	CPV-18	457.2 (18)	551 (21.69)
CPPV-20	CPV-20	508.0 (20)	602 (23.69)
CPPV-24	CPV-24	609.6 (24)	703 (27.69)
CPPV-30	CPV-30	762.0 (30)	856 (33.69)
CPPV-36	CPV-36	914.4 (36)	1008 (39.69)

No incluye tornillería, varillas, clips "U" ni sistemas de fijación • Hardware, threaded rods or anchoring systems are not included

Clip "U" • "U" Form clamp

CU-38-GI

Material y acabado (ver pag 83) • Material & finishes (see page 83)
 Tamaño nominal de varilla roscada • Threaded road size
 Clip "U" • "U" form clamp

Nº de catálogo Catalog number	Tamaño de varilla Road size	A	B	D
CU-38	9.5 (3/8)	110 (4.32)	57 (2.24)	9.5 (3/8)
CU-12	12.7 (½)	133 (5.23)	63 (2.48)	14.3 (9/16)
CU-58	15.9 (5/8)	143 (5.62)	67 (2.63)	14.3 (9/16)

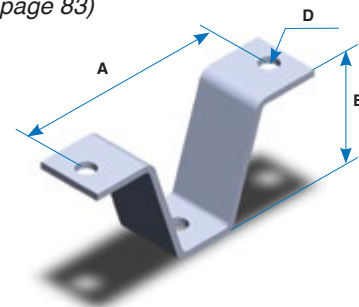

No incluye tornillería, varillas, ni sistemas de fijación • Hardware, threaded rods or anchoring systems are not included

Varilla roscada • Threaded rod

VR-38300 GE

Material y acabado (ver pag 83 excepto GI) • Material & finishes (see page 83 except GI)
 Longitud en metros (solo 3m) • Length in meters (3.0m only)
 Tamaño nominal • Size
 Varilla roscada • Threaded rod

Nº de catálogo Catalog number	Diámetro de varilla Rod size
VR-38	9.5 (3/8)
VR-12	12.7 (½)
VR-58	15.9 (5/8)



No incluye tuercas • Nuts not included

Todas las dimensiones en mm (pulg) • All dimensions are in mm (in)

Soportes colgantes a lateral • Side rail hanging support

SDH-38-GI

- Material y acabado (ver pag 83) • Material & finishes (see page 83)
- Tamaño nominal de varilla roscada • Threaded rod size
- Tipo (sencillo o doble) • Support type (single or double)
- Colgador a lateral • Side rail hanger

N° de catálogo Catalog number		Diámetro de varilla Rod size
Sencillo Single	Doble Double	
SSH-38	SDH-38	9.5 (3/8)
SSH-12	SDH-12	12.7 (1/2)
SSH-58	SDH-58	15.9 (5/8)



Sencillo
Single

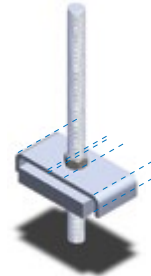

Doble
Double

No incluye tuercas ni varilla • Nuts or threaded rods are not included

Soporte vertical • Vertical support

SV-1GI

- Material y acabado (ver pag 83) • Material & finishes (see page 83)
- Sufijo p/peralte (ver pag 58) • Rail height suffix (see page 58)
- Soporte vertical • Vertical support

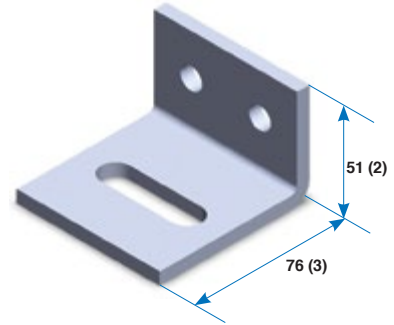
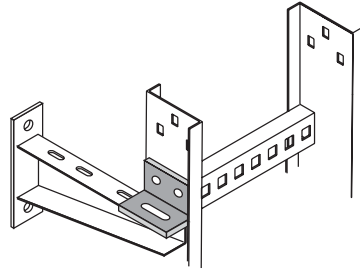
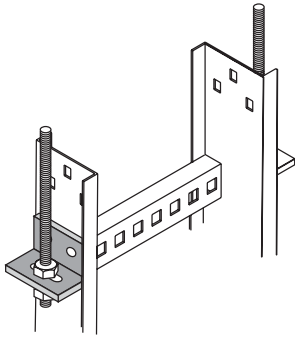

Para usarse con varilla roscada de 12.7 (1/2) no incluida • For 12.7 (1/2) threaded rod not included

Soporte para piso • Floor support

SP-30-1GI

- Material y acabado (ver pag 83) • Material & finishes (see page 83)
- Sufijo p/peralte (ver pag 58) • Rail height suffix (see page 58)
- Altura H al piso "mm" • Height H from floor "mm"
- Soporte para piso • Floor support

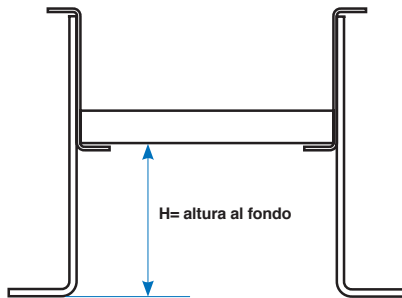

H= altura al fondo

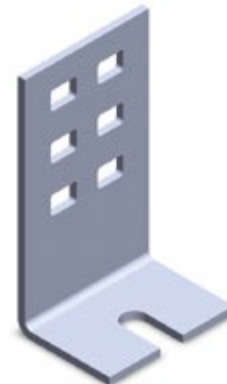

Todas las dimensiones en mm (pulg.) • All dimensions are in mm (in)

Clema para charola • Hold-down clamp

CLAMP-112-GI

Material y acabado (ver pag 83) • *Material & finishes (see page 83)*
 Clema para charola • *Hold-down clamp*

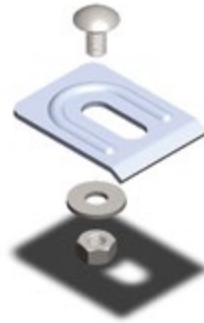

Incluye tornillería • *Hardware included*

Clips angulares • Angular clamp

CAFA-434-GI

Material y acabado (ver pag 83) • *Material & finishes (see page 83)*
 Tipo de clip



Tipo sencillo
 No. catálogo CAFC-234



Tipo reforzado
 No. catálogo CAFL-334



Tipo ajustable
 No. catálogo CAFC-434

Cople para varilla roscada • Threaded coupling

CVR-38-GE

Material y acabado (ver pag 83 excepto GI) • *Material & finishes (see page 83 except GI)*
 Tamaño nominal • *Size*
 Cople para varilla roscada • *Threaded coupling*

Nº de catálogo <i>Catalog number</i>	Diámetro de varilla <i>Rod size</i>
CVR-38	9.5 (3/8)
CVR-12	12.7 (½)
CVR-58	15.9 (5/8)



Los sistemas de apoyo mostrados en esta sección deberán ser colocados de acuerdo a la norma NEMA VE-2

Frames shown in this section should be installed under NEMA VE 2 standard



Todas las dimensiones en mm (pulg). • *All dimensions are in mm (in)*

Sección 4.5

Soportería para cables tipo escalera de fibra de vidrio

El sistema de soportería para cables tipo escalera fabricado en fibra de vidrio marca CROSS LINE es ideal en instalaciones donde se necesita una alta resistencia a la corrosión y donde no se requieran materiales conductores.

Este sistema está diseñado para las condiciones más severas, brindando además el sistema más resistente mecánicamente al tener travesaños atornillados a los perfiles laterales mediante varilla roscada.

Las características que hacen del sistema de fibra de vidrio CROSS LINE, un sistema superior son:

ALTA RESISTENCIA CONTRA RAYOS ULTRAVIOLETA E INTEMPERIE.- Los componentes de poliéster reforzados con fibra de vidrio cuentan con un velo protector aplicado en las superficies exteriores para resistir las inclemencias del tiempo y la acción de los rayos ultravioleta, además, dentro de la formulación, EXCLUSIVA DE CROSS LINE, se integran estabilizadores que aumentan la resistencia, así como pigmentos especiales que sirven como pantalla contra los rayos ultravioleta.

RETARDANTE DE FUEGO.- Por pruebas realizadas en laboratorio y en campo, se demuestra que las charolas evitan la propagación del fuego y auto extinguen cualquier flama en un lapso no mayor a 15 segundos, por otro lado los humos generados durante un evento no son tóxicos a bajas exposiciones.

RESISTENCIA A LA TEMPERATURA.- Las charolas de fibra de vidrio de CROSS LINE tienen un alto grado de resistencia a los cambios de temperatura y a temperaturas extremas, pudiendo ser usadas en cualquier ambiente.

GRAN RESISTENCIA MECÁNICA.- Por su diseño, materiales y método de fabricación estas charolas son más fuertes comparadas con los sistemas metálicos.

FACILIDAD DE INSTALACIÓN.- las charolas de fibra de vidrio son fácilmente perforadas o cortadas con herramientas metálicas, ya que no necesita ser rebabeado. Sus uniones atornillables permiten remover, reponer o trasladar secciones o partes de la instalación.

Section 4.5

Fiber glass ladder type cable tray systems.

CROSS LINE's fiber glass ladder type cable tray system is the best choice for electrical installations where high corrosion resistance and non conductive materials are required.

This system is designed for the most hazardous corrosive environments, being also the most mechanically resistant system as its rungs are bolted to the side rails using threaded rods.

In the following paragraphs we explain why the CROSS LINE fiber glass system is the best choice:

HIGH UV-RAY AND WEATHERING RESISTANCE.- Our fiber glass composite products have an external surface protection veil to protect them against weathering and UV rays.

FLAME RETARDANT.- In field and lab tests, CROSS LINE's fiber glass products prevent flames spreading and it extinguishes in a no longer than 15 seconds period. Generated smoke is not toxic in low exposures.

TEMPERATURE RESISTANCE.- CROSS LINE's fiber glass systems have high temperature's changes resistance grade and can be used in any environment with a good profile.

HIGH MECHANICAL RESISTANCE.- By its design, materials and manufacturing process CROSS LINE's fiber glass systems are stronger than metallic systems.

EASY INSTALLATION.- CROSS LINE's fiber glass systems can be easily drilled or cut using metal working tools does not need to be deburred. It's bolted unions facilitates jobsite removal, replacement and relocate installed parts.

The most important, CROSS LINE's cable tray systems cover all you need for a complete installation. Straight sections, fittings, connections and covers, all are included in our product line, if you don't find the accessory you need please consult our technical department..... We can make it.

!!!EN CHAROLAS SEGUIMOS SIENDO SU MEJOR OPCIÓN!!! · IN CABLE TRAY SYSTEMS WE ARE, AGAIN, YOUR BEST CHOICE!!!

Secciones tipo "C" • "C" Form sections

Peralte Nominal Side rail height	Peralte útil Loading depth	Perfil tipo Rail type	Sufijo p/peralte Rail height Suffix
76. (3)	51 (2)	C, E	3
102 (4)	76 (3)		4
152 (6)	108 (4 1/4)		6
203 (8)	156 (6 1/8)		8
254 (10)	206 (8 1/8)		10

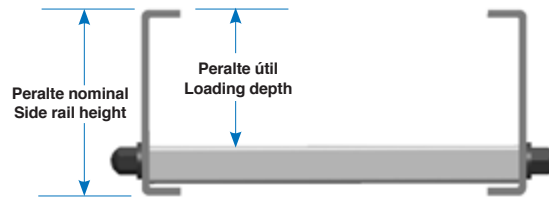

Tramo recto • Straight section

CHC-1209-6FV-6

Longitud 6 = 6.10 m 3 = 3.05 m • Length 6 = 20 ft 3 = 10 ft
 Fibra de vidrio • Fiber glass
 Sufijo p/peralte • Rail height suffix
 Paso • Rung spacing
 Ancho • Width
 Perfil tipo • Rail type
 Tramo recto • Straight section

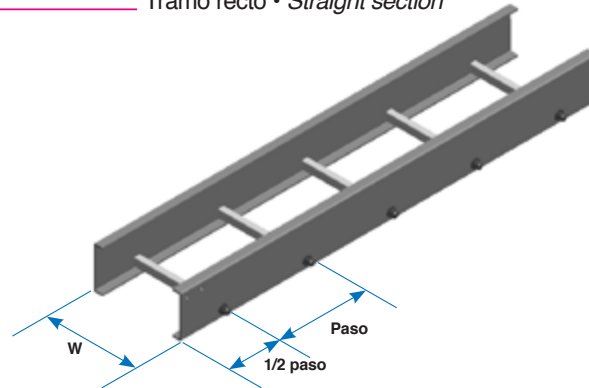

Números de catálogo • Catalog number

Ancho W Width W	Paso Rung spacing			
	152.4 (6)	228.6 (9)	304.8 (12)	457.2 (18)
152.4 (6)	CHC-0606	CHC-0609	CHC-0612	CHC-0618
228.9 (9)	CHC-0906	CHC-0909	CHC-0912	CHC-0918
304.8 (12)	CHC-1206	CHC-1209	CHC-1212	CHC-1218
406.4 (16)	CHC-1606	CHC-1609	CHC-1612	CHC-1618
457.2 (18)	CHC-1806	CHC-1809	CHC-1812	CHC-1818
508.0 (20)	CHC-2006	CHC-2009	CHC-2012	CHC-2018
609.6 (24)	CHC-2406	CHC-2409	CHC-2412	CHC-2418
762.0 (30)	CHC-3006	CHC-3009	CHC-3012	*
914.4 (36)	CHC-3606	CHC-3609	CHC-3612	*

Para longitudes diferentes consulte nuestro departamento de ingeniería. • For any other length please contact our technical department.
 Incluye conectores y tornillería. • Connectors and hardware included

NOTAS :

- En anchos de 762.0 y 914.4 (30" y 36") no se fabrican en paso 457 (18")
- En pasos de 228.6 y 457.2 (9" y 18") se consideran nominales y son ajustados a la longitud de la charola.
- Las longitudes de la charola son de 3.05 m y 6.10 m (10' y 20')

NOTES :

- 762.0 & 914.4 (30" & 36") widths are not available in 457 (18") rung spacing.
- 228.6 & 457.2 (9" & 18") rung space are considered as nominal and they will be adjusted to the straight section length.
- Straight sections are available in 3.05 m & 6.10 m (10' & 20')

Todas las dimensiones en mm (pulg). • All dimensions are in mm (in)

Curva horizontal a 45° y 90° • 45° & 90° Horizontal bend

VHC-12R1290-4FV

- Fibra de vidrio • Fiber glass
- Sufijo p/peralte (ver pag 89) • Rail height suffix (see page 89)
- Ángulo de la curva • Angle bend
- Radio • Radius
- Ancho • Width
- Perfil tipo • Rail type
- Curva horizontal • Horizontal bend

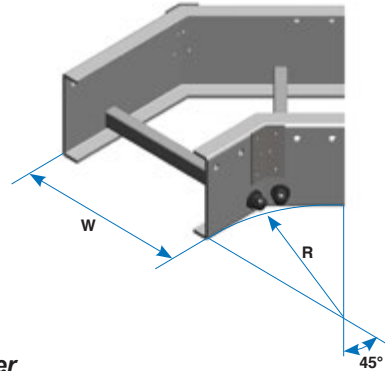
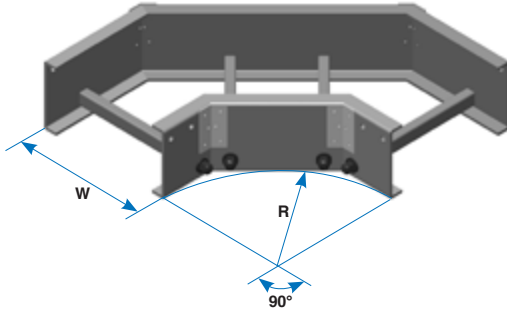

Números de catálogo para curva a 90° • 90° Bend's Catalog number

Ancho W Width W	Radio Radius		
	304.8 (12)	609.6 (24)	914.4 (36)
152.4 (6)	VHC-06R1290	VHC-06R2490	VHC-06R3690
228.9 (9)	VHC-09R1290	VHC-09R2490	VHC-09R3690
304.8 (12)	VHC-12R1290	VHC-12R2490	VHC-12R3690
406.4 (16)	VHC-16R1290	VHC-16R2490	VHC-16R3690
457.2 (18)	VHC-18R1290	VHC-18R2490	VHC-18R3690
508.0 (20)	VHC-20R1290	VHC-20R2490	VHC-20R3690
609.6 (24)	VHC-24R1290	VHC-24R2490	VHC-24R3690
762.0 (30)	VHC-30R1290	VHC-30R2490	VHC-30R3690
914.4 (36)	VHC-36R1290	VHC-36R2490	VHC-36R3690

Números de catálogo para curva a 45° • 45° Bend's Catalog number

Ancho W Width W	Radio Radius		
	304.8 (12)	609.6 (24)	914.4 (36)
152.4 (6)	VHC-06R1245	VHC-06R2445	VHC-06R3645
228.9 (9)	VHC-09R1245	VHC-09R2445	VHC-09R3645
304.8 (12)	VHC-12R1245	VHC-12R2445	VHC-12R3645
406.4 (16)	VHC-16R1245	VHC-16R2445	VHC-16R3645
457.2 (18)	VHC-18R1245	VHC-18R2445	VHC-18R3645
508.0 (20)	VHC-20R1245	VHC-20R2445	VHC-20R3645
609.6 (24)	VHC-24R1245	VHC-24R2445	VHC-24R3645
762.0 (30)	VHC-30R1245	VHC-30R2445	VHC-30R3645
914.4 (36)	VHC-36R1245	VHC-36R2445	VHC-36R3645

Incluye conectores y tornillería • Connectors and hardware included
 Todas las dimensiones en mm (pulg) • All dimensions are in mm (in)

Curva vertical exterior a 45° y 90° • 45° & 90° Outside vertical bend

VEC-12R1290-4FV

- Fibra de vidrio • *Fiber glass*
- Sufijo p/peralte (ver pag 89) • *Rail height suffix (see page 89)*
- Ángulo de la curva • *Angle bend*
- Radio • *Radius*
- Ancho • *Width*
- Perfil tipo • *Rail type*
- Curva vertical exterior • *Outside vertical bend*

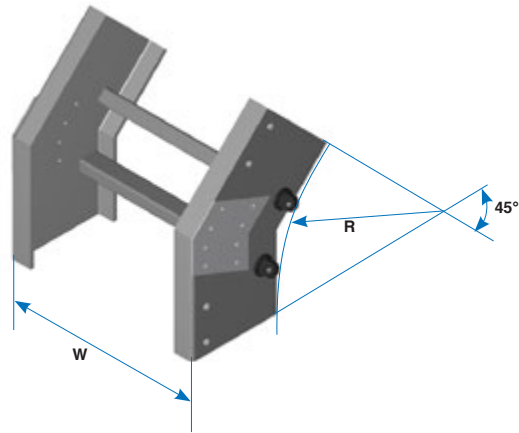
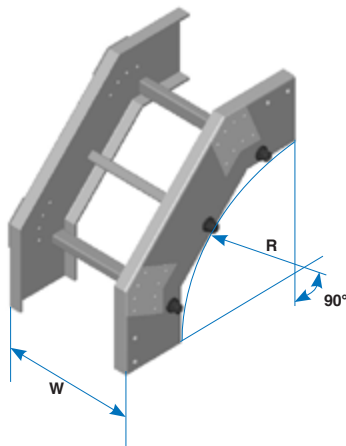

Números de catálogo para curva a 90° • 90° Bend's Catalog number

Ancho W Width W	Radio Radius		
	304.8 (12)	609.6 (24)	914.4 (36)
152.4 (6)	VEC-06R1290	VEC-06R2490	VEC-06R3690
228.9 (9)	VEC-09R1290	VEC-09R2490	VEC-09R3690
304.8 (12)	VEC-12R1290	VEC-12R2490	VEC-12R3690
406.4 (16)	VEC-16R1290	VEC-16R2490	VEC-16R3690
457.2 (18)	VEC-18R1290	VEC-18R2490	VEC-18R3690
508.0 (20)	VEC-20R1290	VEC-20R2490	VEC-20R3690
609.6 (24)	VEC-24R1290	VEC-24R2490	VEC-24R3690
762.0 (30)	VEC-30R1290	VEC-30R2490	VEC-30R3690
914.4 (36)	VEC-36R1290	VEC-36R2490	VEC-36R3690

Números de catálogo para curva a 45° • 45° Bend's Catalog number

Ancho W Width W	Radio Radius		
	304.8 (12)	609.6 (24)	914.4 (36)
152.4 (6)	VEC-06R1245	VEC-06R2445	VEC-06R3645
228.9 (9)	VEC-09R1245	VEC-09R2445	VEC-09R3645
304.8 (12)	VEC-12R1245	VEC-12R2445	VEC-12R3645
406.4 (16)	VEC-16R1245	VEC-16R2445	VEC-16R3645
457.2 (18)	VEC-18R1245	VEC-18R2445	VEC-18R3645
508.0 (20)	VEC-20R1245	VEC-20R2445	VEC-20R3645
609.6 (24)	VEC-24R1245	VEC-24R2445	VEC-24R3645
762.0 (30)	VEC-30R1245	VEC-30R2445	VEC-30R3645
914.4 (36)	VEC-36R1245	VEC-36R2445	VEC-36R3645

Incluye conectores y tornillería • *Connectors and hardware included*
 Todas las dimensiones en mm (pulg) • *All dimensions are in mm (in)*

Curva vertical interior a 45° y 90° • 45° & 90° Inside vertical bend

VIC-12R1290-4FV

- Fibra de vidrio • Fiber glass
- Sufijo p/peralte (ver pag 89) • Rail height suffix (see page 89)
- Ángulo de la curva • Angle bend
- Radio • Radius
- Ancho • Width
- Perfil tipo • Rail type
- Curva vertical interior • Inside vertical bend

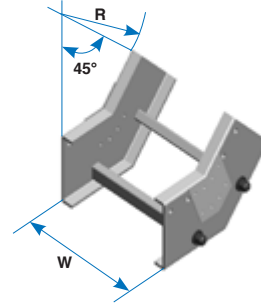
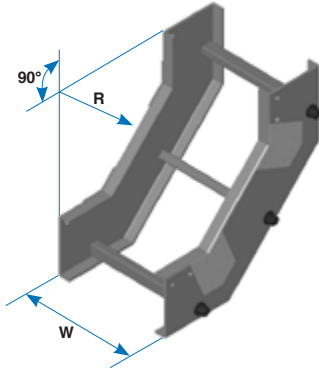

Números de catálogo para curva a 90° • 90° Bend's Catalog number

Ancho W Width W	Radio Radius		
	304.8 (12)	609.6 (24)	914.4 (36)
152.4 (6)	VIC-06R1290	VIC-06R2490	VIC-06R3690
228.9 (9)	VIC-09R1290	VIC-09R2490	VIC-09R3690
304.8 (12)	VIC-12R1290	VIC-12R2490	VIC-12R3690
406.4 (16)	VIC-16R1290	VIC-16R2490	VIC-16R3690
457.2 (18)	VIC-18R1290	VIC-18R2490	VIC-18R3690
508.0 (20)	VIC-20R1290	VIC-20R2490	VIC-20R3690
609.6 (24)	VIC-24R1290	VIC-24R2490	VIC-24R3690
762.0 (30)	VIC-30R1290	VIC-30R2490	VIC-30R3690
914.4 (36)	VIC-36R1290	VIC-36R2490	VIC-36R3690

Números de catálogo para curva a 45° • 45° Bend's Catalog number

Ancho W Width W	Radio Radius		
	304.8 (12)	609.6 (24)	914.4 (36)
152.4 (6)	VIC-06R1245	VIC-06R2445	VIC-06R3645
228.9 (9)	VIC-09R1245	VIC-09R2445	VIC-09R3645
304.8 (12)	VIC-12R1245	VIC-12R2445	VIC-12R3645
406.4 (16)	VIC-16R1245	VIC-16R2445	VIC-16R3645
457.2 (18)	VIC-18R1245	VIC-18R2445	VIC-18R3645
508.0 (20)	VIC-20R1245	VIC-20R2445	VIC-20R3645
609.6 (24)	VIC-24R1245	VIC-24R2445	VIC-24R3645
762.0 (30)	VIC-30R1245	VIC-30R2445	VIC-30R3645
914.4 (36)	VIC-36R1245	VIC-36R2445	VIC-36R3645

Incluye conectores y tornillería • Connectors and hardware included
 Todas las dimensiones en mm (pulg) • All dimensions are in mm (in)

“T” Horizontal • Horizontal tee

THC-12R12-4FV

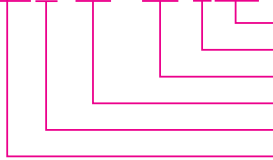

Fibra de vidrio • *Fiber glass*
 Sufijo p/peralte (ver pag 89) • *Rail height suffix (see page 89)*
 Radio • *Radius*
 Ancho • *Width*
 Perfil tipo • *Rail type*
 “T” horizontal • *Horizontal Tee*

Números de catálogo • *Catalog number*

Ancho W Width W	Radio Radius		
	304.8 (12)	609.6 (24)	914.4 (36)
152.4 (6)	THC-06R12	THC-06R24	THC-06R36
228.9 (9)	THC-09R12	THC-09R24	THC-09R36
304.8 (12)	THC-12R12	THC-12R24	THC-12R36
406.4 (16)	THC-16R12	THC-16R24	THC-16R36
457.2 (18)	THC-18R12	THC-18R24	THC-18R36
508.0 (20)	THC-20R12	THC-20R24	THC-20R36
609.6 (24)	THC-24R12	THC-24R24	THC-24R36
762.0 (30)	THC-30R12	THC-30R24	THC-30R36
914.4 (36)	THC-36R12	THC-36R24	THC-36R36

Incluye conectores y tornillería • *Connectors and hardware included*

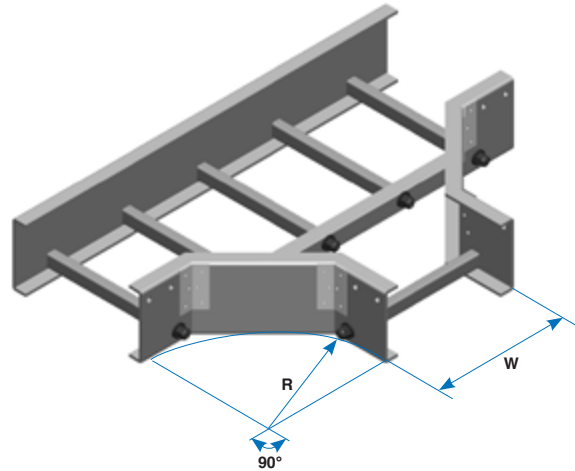

“X” Horizontal • Horizontal cross

XHC-12R12-4FV

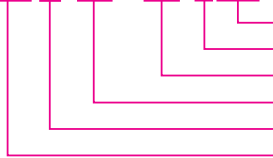

Fibra de vidrio • *Fiber glass*
 Sufijo p/peralte (ver pag 89) • *Rail height suffix (see page 89)*
 Radio • *Radius*
 Ancho • *Width*
 Perfil tipo • *Rail type*
 “X” horizontal • *Horizontal cross*

Números de catálogo • *Catalog number*

Ancho W Width W	Radio Radius		
	304.8 (12)	609.6 (24)	914.4 (36)
152.4 (6)	XHC-06R12	XHC-06R24	XHC-06R36
228.9 (9)	XHC-09R12	XHC-09R24	XHC-09R36
304.8 (12)	XHC-12R12	XHC-12R24	XHC-12R36
406.4 (16)	XHC-16R12	XHC-16R24	XHC-16R36
457.2 (18)	XHC-18R12	XHC-18R24	XHC-18R36
508.0 (20)	XHC-20R12	XHC-20R24	XHC-20R36
609.6 (24)	XHC-24R12	XHC-24R24	XHC-24R36
762.0 (30)	XHC-30R12	XHC-30R24	XHC-30R36
914.4 (36)	XHC-36R12	XHC-36R24	XHC-36R36

Incluye conectores y tornillería • *Connectors and hardware included*

Todas las dimensiones en mm (pulg) • *All dimensions are in mm (in)*

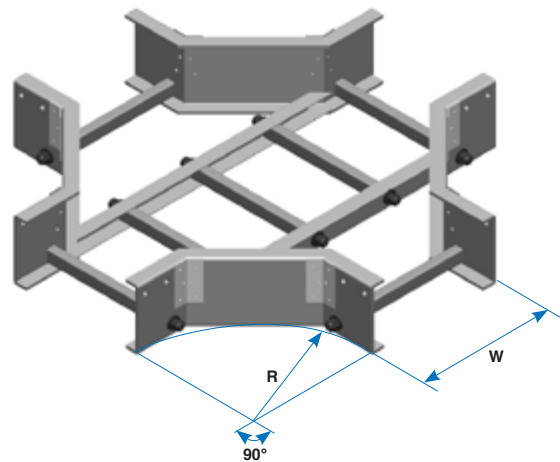

Reducciones • Reducers

RLC-1209-4FV



- Fibra de vidrio • *Fiber glass*
- Sufijo p/peralte (ver pag 89) • *Rail height suffix (see page 89)*
- Ancho menor • *Smaller width*
- Ancho mayor • *Larger width*
- Perfil tipo (ver pag 89) • *Rail type (see page 89)*
- Reducción • *Reducer*
- RL = Recta • *Straight*
- RLD = Derecha • *Right*
- RLI = Izquierda • *Left*

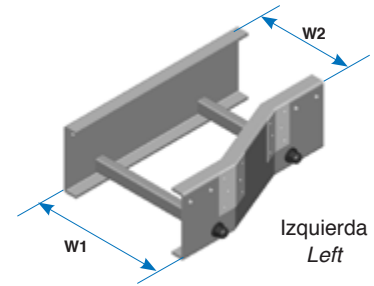
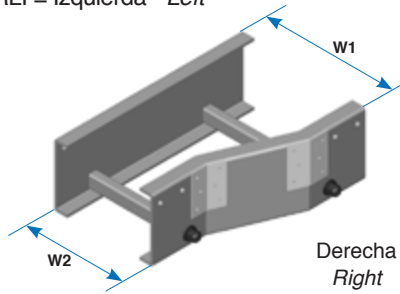
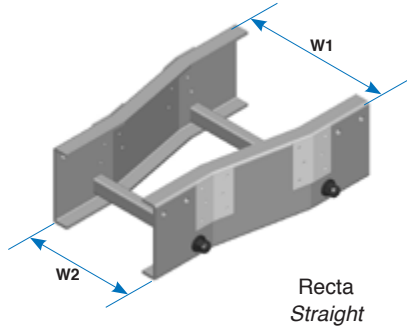

N° de catálogo reducciones rectas • *Straight reducer catalog number*

Ancho W1 <i>Width W1</i>	Ancho menor W2 <i>Smaller width W2</i>								
	152.4 (6)	228.9 (9)	304.8 (12)	406.4 (16)	457.2 (18)	508.0 (20)	609.6 (24)	762.0 (30)	
152.4 (6)									
228.9 (9)	RLC-0906								
304.8 (12)	RLC-1206	RLC-1209							
406.4 (16)	RLC-1606	RLC-1609	RLC-1612						
457.2 (18)	RLC-1806	RLC-1809	RLC-1812	RLC-1816					
508.0 (20)	RLC-2006	RLC-2009	RLC-2012	RLC-2016	RLC-2018				
609.6 (24)	RLC-2406	RLC-2409	RLC-2412	RLC-2416	RLC-2418	RLC-2420			
762.0 (30)	RLC-3006	RLC-3009	RLC-3012	RLC-3016	RLC-3018	RLC-3020	RLC-3024		
914.4 (36)	RLC-3606	RLC-3609	RLC-3612	RLC-3616	RLC-3618	RLC-3620	RLC-3624	RLC-3630	

N° de catálogo reducciones derechas • *Right reducer catalog number*

Ancho W1 <i>Width W1</i>	Ancho menor W2 <i>Smaller width W2</i>								
	152.4 (6)	228.9 (9)	304.8 (12)	406.4 (16)	457.2 (18)	508.0 (20)	609.6 (24)	762.0 (30)	
152.4 (6)									
228.9 (9)	RLDC-0906								
304.8 (12)	RLDC-1206	RLDC-1209							
406.4 (16)	RLDC-1606	RLDC-1609	RLDC-1612						
457.2 (18)	RLDC-1806	RLDC-1809	RLDC-1812	RLDC-1816					
508.0 (20)	RLDC-2006	RLDC-2009	RLDC-2012	RLDC-2016	RLDC-2018				
609.6 (24)	RLDC-2406	RLDC-2409	RLDC-2412	RLDC-2416	RLDC-2418	RLDC-2420			
762.0 (30)	RLDC-3006	RLDC-3009	RLDC-3012	RLDC-3016	RLDC-3018	RLDC-3020	RLDC-3024		
914.4 (36)	RLDC-3606	RLDC-3609	RLDC-3612	RLDC-3616	RLDC-3618	RLDC-3620	RLDC-3624	RLDC-3630	

N° de catálogo reducciones izquierdas • *Left reducer catalog number*

Ancho W1 <i>Width W1</i>	Ancho menor W2 <i>Smaller width W2</i>								
	152.4 (6)	228.9 (9)	304.8 (12)	406.4 (16)	457.2 (18)	508.0 (20)	609.6 (24)	762.0 (30)	
152.4 (6)									
228.9 (9)	RLIC-0906								
304.8 (12)	RLIC-1206	RLIC-1209							
406.4 (16)	RLIC-1606	RLIC-1609	RLIC-1612						
457.2 (18)	RLIC-1806	RLIC-1809	RLIC-1812	RLIC-1816					
508.0 (20)	RLIC-2006	RLIC-2009	RLIC-2012	RLIC-2016	RLIC-2018				
609.6 (24)	RLIC-2406	RLIC-2409	RLIC-2412	RLIC-2416	RLIC-2418	RLIC-2420			
762.0 (30)	RLIC-3006	RLIC-3009	RLIC-3012	RLIC-3016	RLIC-3018	RLIC-3020	RLIC-3024		
914.4 (36)	RLIC-3606	RLIC-3609	RLIC-3612	RLIC-3616	RLIC-3618	RLIC-3620	RLIC-3624	RLIC-3630	

Incluye conectores y tornillería • *Connectors and hardware included*
 Todas las dimensiones en mm (pulg) • *All dimensions are in mm (in)*

“T” Vertical • Vertical tee

TVC-12R12-4FV

- Fibra de vidrio • *Fiber glass*
- Sufijo p/peralte (ver pag 89) • *Rail height suffix (see page 89)*
- Radio • *Radius*
- Ancho • *Width*
- Perfil tipo • *Rail type*
- “T” vertical • *Vertical Tee*

N° de catálogo • *Catalog number*

Ancho W Width W	Radio Radius		
	304.8 (12)	609.6 (24)	914.4 (36)
152.4 (6)	TVC-06R12	TVC-06R24	TVC-06R36
228.9 (9)	TVC-09R12	TVC-09R24	TVC-09R36
304.8 (12)	TVC-12R12	TVC-12R24	TVC-12R36
406.4 (16)	TVC-16R12	TVC-16R24	TVC-16R36
457.2 (18)	TVC-18R12	TVC-18R24	TVC-18R36
508.0 (20)	TVC-20R12	TVC-20R24	TVC-20R36
609.6 (24)	TVC-24R12	TVC-24R24	TVC-24R36
762.0 (30)	TVC-30R12	TVC-30R24	TVC-30R36
914.4 (36)	TVC-36R12	TVC-36R24	TVC-36R36

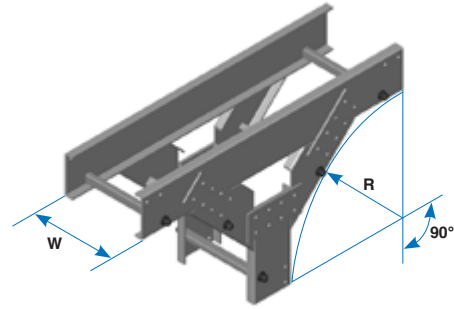

Incluye conectores y tornillería • *Connectors and hardware included*

Curva vertical ajustable • Vertical adjustable bend

VAC-12R12-4FV

- Fibra de vidrio • *Fiber glass*
- Sufijo p/peralte (ver pag 89) • *Rail height suffix (see page 89)*
- Radio • *Radius*
- Ancho • *Width*
- Perfil tipo • *Rail type*
- Curva vertical ajustable • *Vertical adjustable bend*

N° de catálogo • *Catalog number*

Ancho W Width W	Radio Radius		
	304.8 (12)	609.6 (24)	914.4 (36)
152.4 (6)	VAC-06R12	VAC-06R24	VAC-06R36
228.9 (9)	VAC-09R12	VAC-09R24	VAC-09R36
304.8 (12)	VAC-12R12	VAC-12R24	VAC-12R36
406.4 (16)	VAC-16R12	VAC-16R24	VAC-16R36
457.2 (18)	VAC-18R12	VAC-18R24	VAC-18R36
508.0 (20)	VAC-20R12	VAC-20R24	VAC-20R36
609.6 (24)	VAC-24R12	VAC-24R24	VAC-24R36
762.0 (30)	VAC-30R12	VAC-30R24	VAC-30R36
914.4 (36)	VAC-36R12	VAC-36R24	VAC-36R36

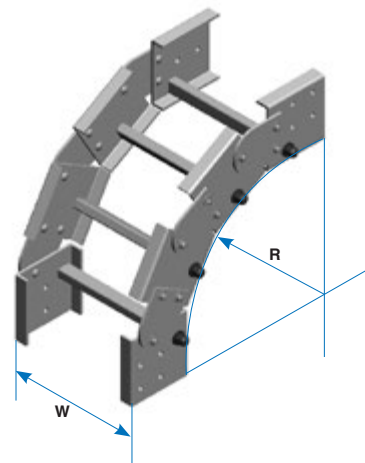

Incluye conectores y tornillería • *Connectors and hardware included*

Todas las dimensiones en mm (pulg) • *All dimensions are in mm (in)*

Conectores • Connectors

AE-4FV

Fibra de vidrio • Fiber glass
 Sufijo p/peralte (ver pag 89) • Rail height suffix (see page 89)
 Conector tipo • Connector type



AR Tipo recto
 Splice plate AR TYPE

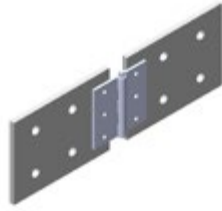

AH Tipo horizontal ajustable
 Horizontal adjustable AH TYPE



EA Tipo vertical ajustable
 Vertical adjustable EA TYPE



AE Conector de expansión
 Expansion connector AE TYPE

Incluye tornillería de acero inoxidable encapsulados en fibra de vidrio • Stainless steel encased in fiber glass bolts included.

Conectores verticales de ángulo fijo • Fixed angle vertical connectors

AV30-4FV

Fibra de vidrio • Fiber glass
 Sufijo p/peralte (ver pag 89) • Rail height suffix (see page 89)
 Conector tipo • Connector type

Ángulo Angle	Conector tipo Connector type
22.5°	AV22
30°	AV30
45°	AV45
60°	AV60
90°	AV90

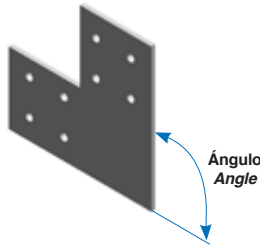

Incluye tornillería de acero inoxidable encapsulados en fibra de vidrio • Stainless steel encased in fiber glass bolts included.

Conectores horizontales de ángulo fijo • Fixed angle horizontal connectors

AHF30-4FV

Fibra de vidrio • Fiber glass
 Sufijo p/peralte (ver pag 89) • Rail height suffix (see page 89)
 Conector tipo • Connector type

Ángulo Angle	Conector tipo Connector type
22.5°	AHF22
30°	AHF30
45°	AHF45
60°	AHF60
90°	AHF90

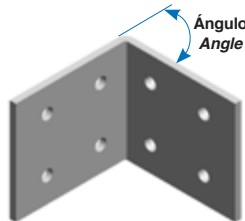

Incluye tornillería de acero inoxidable encapsulados en fibra de vidrio • Stainless steel encased in fiber glass bolts included.
 SUGERENCIA DE USO: El conector AHF90 puede ser usado en pares como CONECTOR A CAJA.

Placa terminal • Blind end

PTR-12-4FV

- Fibra de vidrio • Fiber glass
- Sujijo p/peralte (ver pag 89) • Rail height suffix (see page 89)
- Ancho de la charola • Tray width
- Tapa terminal • Blind end

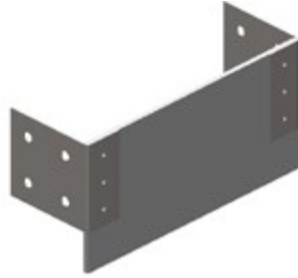

Incluye tornillería de acero inoxidable encapsados en fibra de vidrio • Stainless steel encased in fiber glass bolts included.

Todas las dimensiones en mm (pulg) • All dimensions are in mm (in)

Tapa recta sin ventilación • Non vented flat cover

TR THC-12R12-4FV

- Fibra de vidrio • Fiber glass
- Sujijo p/peralte (ver pag 89) • Rail height suffix (see page 89)
- No de catálogo de el producto a recubrir • Covered product catalog number
- Tapa recta no ventilada • Non vented flat cover

La longitud de la tapa para tramo recto es de 3.048 m.

Cada tapa para tramo recto incluye 6 clips de sujeción de acero inoxidable.

El número de clips para tapas de accesorios estará en función del accesorio.

For straight section, the cover length is 3.048 m (10 ft) and 6 cover clamps are included.

For fittings the cover clamps quantity is according to the fitting.



Tapa recta con ventilación • Vented flat cover

TRV THC-12R12-4FV

- Fibra de vidrio • Fiber glass
- Sujijo p/peralte (ver pag 89) • Rail height suffix (see page 89)
- No de catálogo de el producto a recubrir • Covered product catalog number
- Tapa recta ventilada • Vented flat cover

La longitud de la tapa para tramo recto es de 3.048 m.

Cada tapa para tramo recto incluye 4 pares de juegos de separadores.

El número de clips para tapas de accesorios estará en función del accesorio.

For straight section, the cover length is 3.048 m (10 ft) and 4 pairs cover clamps kits are included.

For fittings the cover clamp quantity is according to the fitting.

The anchorage holes should be field made.



Tapa a dos aguas con ventilación • Vented peaked cover

TA CHC-1209-4FV

- Fibra de vidrio • Fiber glass
- Sufijo p/peralte (ver pag 89) • Rail height suffix (see page 89)
- No de catálogo de el producto a recubrir • Covered product catalog number
- Tapa a dos aguas ventilada • Vented peaked cover

La longitud de la tapa es de 3.048 m.

Este tipo de tapa no está disponible para accesorios.

The cover length is 3.048 m (10 ft) and 4 pairs of kits cover clamps are included.

This cover type in not available for fitting.

The anchorage holes should be field made.

Todas las dimensiones en mm (pulg) • All dimensions are in mm (in)

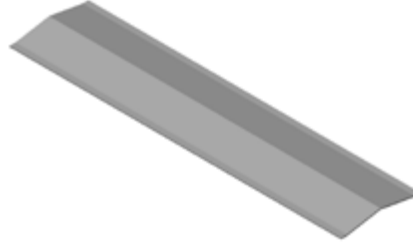

Barreras separadoras • Barrier strips

BSCH-4FV

- Fibra de vidrio • Fiber glass
- Sufijo p/peralte (ver pag 89) • Rail height suffix (see page 89)
- Barrera separadora • Barrier strip

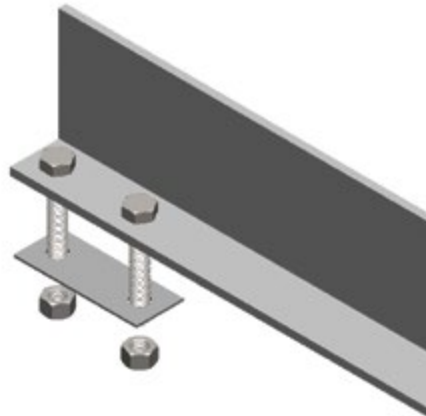

Las barreras separadoras para tramos rectos se surten en Longitudes de 3.048 metros y deberán ser instaladas en campo.

Cada barrera separadora incluye 3 juegos de clips (placa, y tornillería).

Debido a que es imposible determinar con anticipación la posición de la barrera en un accesorio, cuando se requiera se deberá solicitar barreras para tramos rectos y deberán ser cortadas e instaladas en campo.

For straight section, the barrier length is 3.048 m (10 ft) and 3 barrier clamp kits (platter and hardware) are included.

The barriers should be field installed.

Barrera separadora para accesorios horizontales • Horizontal accessories barrier strip

BSH-48 4FV

- Fibra de vidrio • Fiber glass
- Sufijo p/peralte (ver pag 89) • Rail height suffix (see page 89)
- Largo en pulgadas (48" y 72") • Length in inches (48" & 72")
- Barrera separadora accesorios horizontales • Horizontal accessories barrier strip

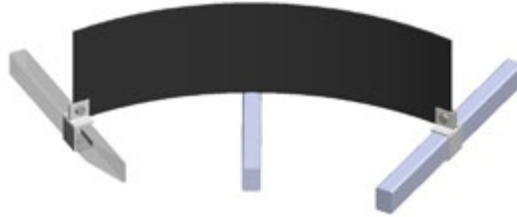

Incluye 3 clips de fijación • Includes 3 fixation clips

Barrera separadora para accesorios verticales • Vertical accessories barrier strip

BSVEC-R1290 4FV

- Fibra de vidrio • Fiber glass
- Sufijo p/peralte (ver pag 89) • Rail height suffix (see page 89)
- Ángulo de la curva • Bend angle
- Radio • Radius
- Tipo de curva • Bend type
- Barrera separadora • Barrier strip



Incluye clips de fijación • Fixation clips included

Bajada para cables • Drop out

BC-24R05AI P/FV

- Material y acabado • Material & finishes
- Radio de la bajada • Drop out radius
- Ancho de la charola • Tray width
- Bajada para cable • Drop out



No requiere tornillería de fijación • Hardware not needed.

Clema para charola • Hold-down clamp

CLAMP-112AI P/FV



Esta clema es fabricada en acero inoxidable
The clamp is made of stainless steel

CLAMP-112FV

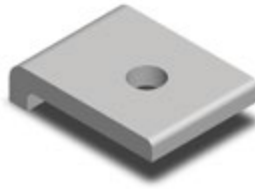

Clemas en fibra de vidrio. Incluyen tornillería en acero inoxidable encapsulada en fibra de vidrio.
Clamps made of fiber glass. Stainless steel fiber glass encased hardware included.

CLAMPGUIA-112FV



Clema en acero inoxidable, incluye tornillería • *Clamp made of stainless steel, hardware included.*

Canaleta • Channel tray

CHSV-4305-FV

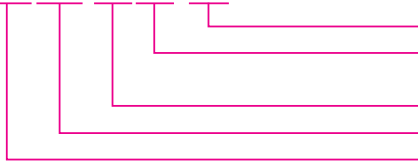

Fibra de vidrio • *Fiber glass*
 Longitud 305 = 3.048m (10 ft), 610 = 6.096m (20 ft)
Length 305 = 3.048m (10 ft), 610 = 6.096m (20 ft)
 Ancho • *Width*
 Tipo SV= liso CV = perforado • *Type SV= solid CV= slotted*
 Canaleta • *Channel tray*

Ancho W Width W	Altura P High P	Tipo liso <i>Solid type</i>		Tipo perforado <i>Slotted type</i>	
		3.048 (10 ft)	6.096 (20 ft)	3.048 (10 ft)	6.096 (20 ft)
76 (3)	25 (1)	CHSV-3305FV	CHSV-3610FV	CHCV-3305FV	CHCV-3610FV
102 (4)	32 (1 1/4)	CHSV-4305FV	CHSV-4610FV	CHCV-4305FV	CHCV-4610FV
152 (6)	32 (1 1/4)	CHSV-6305FV	CHSV-6610FV	CHCV-6305FV	CHCV-6610FV
203 (8)	32 (1 1/4)	CHSV-8305FV	CHSV-8610FV	CHCV-8305FV	CHCV-8610FV
254 (10)	51 (2)	CHSV-10305FV	CHSV-10610FV	CHCV-10305FV	CHCV-10610FV

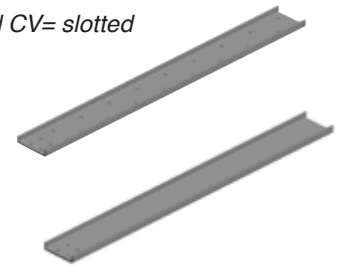

Para curvas y derivaciones utilizar los conectores mostrados en la pag 96 donde el ancho del canal equivale al peralte de la charola tipo escalera.
For fittings use the connectors showed in page 96 where the channel tray width is the same as the rail height in ladder tray.

Un conector tipo AR y tornillería incluidos • *AR connector type and hardware included*
 Todas las dimensiones en mm (pulg) • *All dimensions are in mm (in)*

Unicanal de fibra de vidrio • Fiber glass unistrut

LU-1000FV



Fibra de vidrio • *Fiber glass*
 Tipo unicanal (1000 y 3300) • *Channel type (1000 & 3300)*
 Tramo recto unicanal • *Straight channel*

No. catálogo <i>Catalog number</i>	Ancho <i>Width</i>	Altura <i>Height</i>
LU-1000	44.45 (1.750")	44.45 (1.750")
LU-3300		25.05 (0.986")

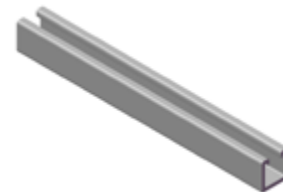

Longitud 3.05m • *Length: 3.05m.*
 Todas las dimensiones en mm (pulg) • *All dimensions are in mm (in)*

Ménsula para montaje en pared • Wall cantilever bracket

MPP-06 FV

Material y acabado • *Material & finishes*
 Ancho de charola • *Cable tray width*
 Ménsula para pared • *Wall supported bracket*

Ancho de charola <i>Tray width</i>	A	No de catálogo <i>Catalog number</i>	L
101.6 (4)	254 (10)	MPP-04	165.1 (6.5)
152.4 (6)		MPP-06	215.9 (8.5)
228.9 (9)		MPP-09	292.1 (11.5)
304.8 (12)		MPP-12	368.3 (14.5)
406.4 (16)	304.8 (12)	MPP-16	469.9 (18.5)
457.2 (18)		MPP-18	520.7 (20.5)
508.0 (20)		MPP-20	571.5 (22.5)
609.6 (24)		MPP-24	673.1 (26.5)
762.0 (30)		MPP-30	825.5 (32.5)
914.4 (36)		MPP-36	977.9 (38.5)

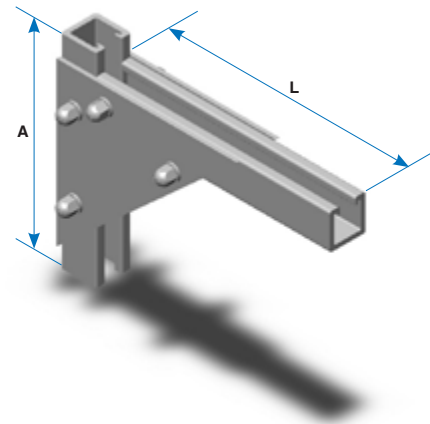

No incluye clemas ni sistemas de fijación. • *Hardware, clamps or anchoring system are not included.*

Canal horizontal para trapecio • Horizontal channel for support

CPV-06FV

Material y acabado • *Material & finishes*
 Ancho de charola • *Cable tray width*
 Canal horizontal para trapecio • *Horizontal channel for support*

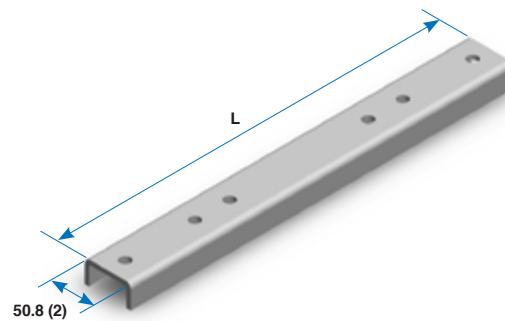
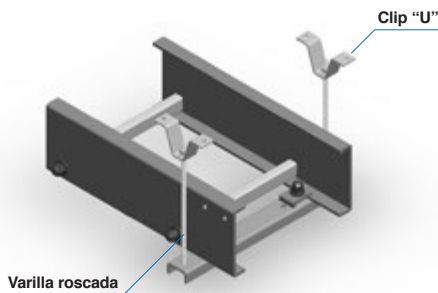

N° de catálogo • *Catalog number*

Canal horizontal profundo <i>Deep horizontal channel</i>	Ancho de charola <i>Tray width</i>	L
CPV-04	101.6 (4)	216 (8.50)
CPV-06	152.4 (6)	267 (10.50)
CPV-09	228.9 (9)	343 (13.50)
CPV-12	304.8 (12)	419 (16.50)
CPV-16	406.4 (16)	521 (20.50)
CPV-18	457.2 (18)	572 (22.50)
CPV-20	508.0 (20)	622 (24.50)
CPV-24	609.6 (24)	724 (28.50)
CPV-30	762.0 (30)	876 (34.50)
CPV-36	914.4 (36)	1029 (40.50)

No incluye tornillería, varillas, clips "U" ni sistemas de fijación • *Hardware, threaded rods or anchoring systems are not included.*

Sección 4.6

Soportería para cables tipo marino

Section 4.6

Marine type cable tray system.

Tramo recto • Straight section

CHM-100-35GI

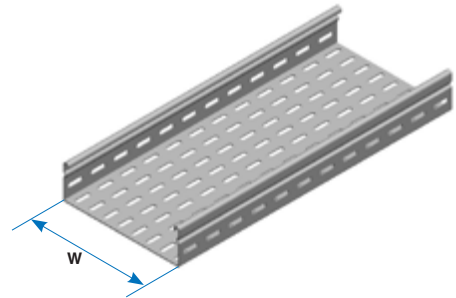
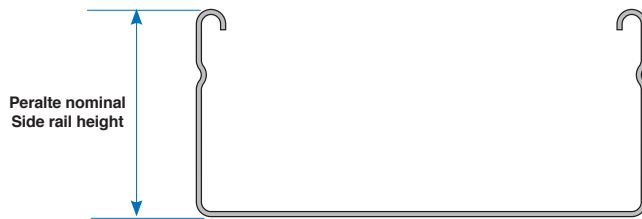
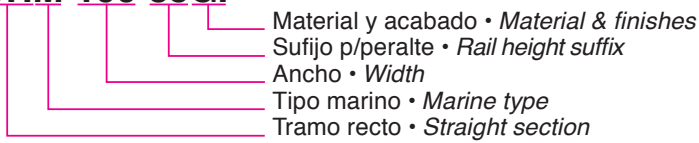

N° de catálogo • *Catalog number*

Ancho W Width W	Peralte Side rail height			
	35	60	85	110
100	CHM-100-35	CHM-100-60	CHM-100-85	CHM-100-110
200	CHM-200-35	CHM-200-60	CHM-200-85	CHM-200-110
300	CHM-300-35	CHM-300-60	CHM-300-85	CHM-300-110
400		CHM-400-60	CHM-400-85	CHM-400-110
500		CHM-500-60	CHM-500-85	CHM-500-110
600		CHM-600-60	CHM-600-85	CHM-600-110

Longitud estándar 3.0 m.
Para longitudes diferentes consulte nuestro departamento de técnico.

Standard length 3.000 m
For any other length please contact our technical department

Incluye conector(es) y tornillería.

Connector(s) and hardware included

Materiales y acabados:

A: Aluminio aleación AA-3003 acabado natural
GI: Lámina galvanizada
AI: Acero inoxidable

Materials & finishes:

A: AA-3003 natural finished aluminum
GI: Galvanized sheet
AI: Stainless steel

Para materiales y acabados no indicados consulte nuestro departamento de ingeniería.

For materials and finishes not shown please consult our technical department.

Todas las dimensiones en mm (pulg)

All dimensions are in mm (in)

Curva horizontal a 45° y 90° • 45° & 90° Horizontal bend

VHM-100R25090-35GI

Material y acabado (ver pag 102) • *Material & finish (see page 102)*
 Sufijo p/peralte (ver pag 102) • *Rail height suffix (see page 102)*
 Ángulo de la curva • *Angle bend*
 Radio (disponible en 250) • *Radius (available in 10")*
 Ancho • *Width*
 Tipo marino • *Marine type*
 Curva horizontal • *Horizontal bend*

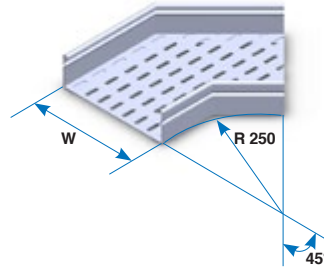
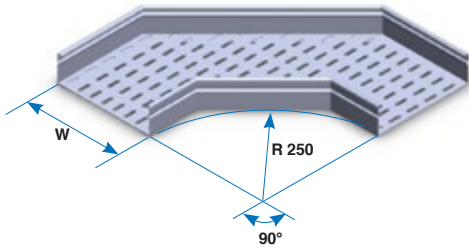

Ancho W Width W	Ángulo Angle	
	45°	90°
100	VHM-100R25045	VHM-100R25045
200	VHM-200R25045	VHM-200R25045
300	VHM-300R25045	VHM-300R25045
400	VHM-400R25045	VHM-400R25045
500	VHM-500R25045	VHM-500R25045
600	VHM-600R25045	VHM-600R25045

Incluye conector(es) y tornillería • *Connector(s) and hardware included*

“T” Horizontal • Horizontal “TEE”

THM-100R250-35GI

Material y acabado (ver pag 102) • *Material & finish (see page 102)*
 Sufijo p/peralte (ver pag 102) • *Rail height suffix (see page 102)*
 Radio (disponible en 250) • *Radius (available in 10")*
 Ancho • *Width*
 Tipo marino • *Marine type*
 “T” horizontal • *Horizontal “Tee”*

No. de catálogo Catalog number	Ancho W Width W
THM-100R250	100
THM-200R250	200
THM-300R250	300
THM-400R250	400
THM-500R250	500
THM-600R250	600

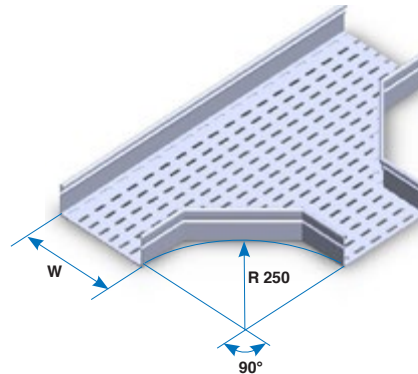

Incluye conector(es) y tornillería • *Connector(s) and hardware included*

Todas las dimensiones en mm (pulg) • *All dimensions are in mm (in)*

“EQUIS” Horizontal • Horizontal cross

XHM-100R250-35GI

- Material y acabado (ver pag 102) • *Material & finish (see page 102)*
- Sufijo p/peralte (ver pag 102) • *Rail height suffix (see page 102)*
- Radio (disponible en 250) • *Radius (available in 10")*
- Ancho • *Width*
- Tipo marino • *Marine type*
- Equis horizontal • *Horizontal cross*

No. de catálogo Catalog number	Ancho W Width W
XHM-100R250	100
XHM-200R250	200
XHM-300R250	300
XHM-400R250	400
XHM-500R250	500
XHM-600R250	600

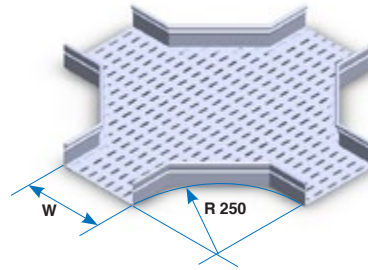

Incluye conector(es) y tornillería • *Connector(s) and hardware included*
 Todas las dimensiones en mm (pulg) • *All dimensions are in mm (in)*

Reducciones • Reducer

RLM-300200-35GI

- Material y acabado (ver pag 102) • *Material & finish (see page 102)*
- Sufijo p/peralte (ver pag 102) • *Rail height suffix (see page 102)*
- Ancho menor • *Smallest width*
- Ancho mayor • *Largest width*
- Tipo marino • *Marine type*
- Reducción • *Reducer*

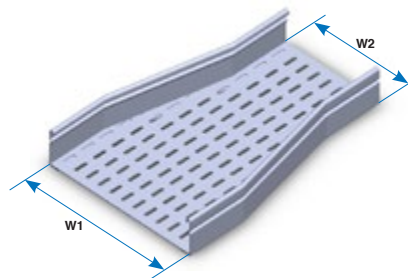

N° de catálogo reducciones rectas • *Straight reducer catalog number*

Ancho W1 Width W1	Ancho menor W2 Smallest width W2				
	100	200	300	400	500
200	RLM-200100				
300	RLM-300100	RLM-300200			
400	RLM-400100	RLM-400200	RLM-400300		
500	RLM-500100	RLM-500200	RLM-500300	RLM-500400	
600	RLM-600100	RLM-600200	RLM-600300	RLM-600400	RLM-600500

Incluye conector(es) y tornillería • *Connector(s) and hardware included*
 Todas las dimensiones en mm (pulg) • *All dimensions are in mm (in)*

Curva vertical ajustable • Vertical adjustable bend

VAM-100R200-35GI

- Material y acabado (ver pag 102) • *Material & finish (see page 102)*
- Sufijo p/peralte (ver pag 102) • *Rail height suffix (see page 102)*
- Radio • *Radius*
- Ancho • *Width*
- Tipo marino • *Marine type*
- Curva vertical ajustable • *Vertical adjustable bend*

Cantidad de elementos ajustables • Adjustable element quantity

Radio Radius	Elementos ajustables Adjustable elements
200	1
350	2
500	3
625	4

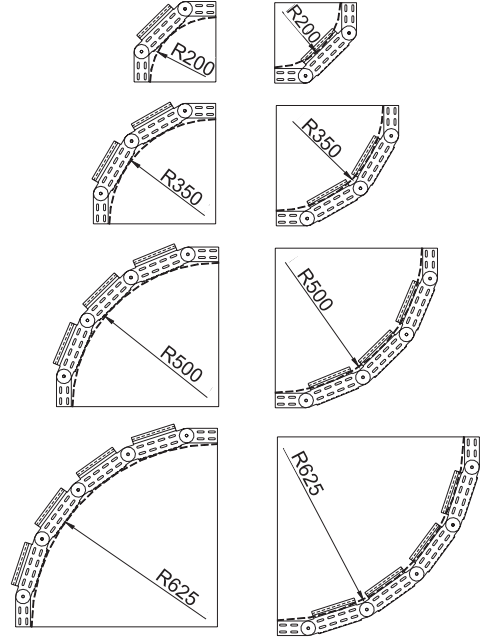

Ancho W Width W	No. de catálogo Catalog Number			
	Radio Radius			
	200	350	500	625
100	VAM-100R200	VAM-100R350	VAM-100R500	VAM-100R625
200	VAM-200R200	VAM-200R350	VAM-200R500	VAM-200R625
300	VAM-300R200	VAM-300R350	VAM-300R500	VAM-300R625
400	VAM-400R200	VAM-400R350	VAM-400R500	VAM-400R625
500	VAM-500R200	VAM-500R350	VAM-500R500	VAM-500R625
600	VAM-600R200	VAM-600R350	VAM-600R500	VAM-600R625

Incluye 4 conectores EACM con tornillería • *Four EACM connectors and hardware included*

Elemento vertical ajustable • Vertical adjustable element

VAM-10035GI

- Material y acabado (ver pag 102) • *Material & finish (see page 102)*
- Sufijo p/peralte (ver pag 102) • *Rail height suffix (see page 102)*
- Ancho • *Width*
- Tipo marino • *Marine type*
- Elemento vertical ajustable • *Vertical adjustable element*

No. de catálogo Catalog number	Ancho W Width W
VAM-100R250	100
VAM-200R250	200
VAM-300R250	300
VAM-400R250	400
VAM-500R250	500
VAM-600R250	600



No incluye conectores ni tornillería • *Connectors and hardware are not included*

Conector vertical ajustable • Vertical adjustable connector

EACM-35GI

- Material y acabado (ver pag 102) • *Material & finish (see page 102)*
- Sufijo p/peralte (ver pag 102) • *Rail height suffix (see page 102)*
- Tipo marino • *Marine type*
- Conector para curva vertical ajustable • *Vertical adjustable bend connector*



Todas las dimensiones en mm (pulg) • *All dimensions are in mm (in)*
Incluye tornillería • *Hardware included*

Tapas • Covers

TCV THM-100R250-GI

Material y acabado (ver pag 102) • *Material & finish (see page 102)*
 No de catálogo del producto a cubrir • *Covered product catalog number*
 Tapa con ceja y vena • *Flanged and streaked cover*

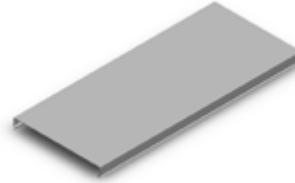

No requiere clips o tornillería • *Clamps and hardware are not required*

Conectores • Connectors

ARM-35GI

Material y acabado (ver pag 102) • *Material & finish (see page 102)*
 Sufijo p/peralte (ver pag 102) • *Rail height suffix (see page 102)*
 Tipo marino • *Marine type*
 Conector tipo • *Connector type*

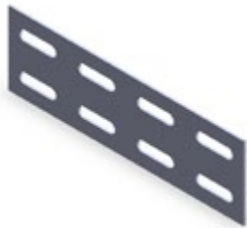

AR Tipo recto
Splice plate AR TYPE



AH Tipo horizontal ajustable
Horizontal adjustable AH TYPE



EA Tipo vertical ajustable
Vertical adjustable EA TYPE

Incluye tornillería • *Hardware included*

Tapa terminal • Blind end

PTRM-100-35GI

Material y acabado (ver pag 102) • *Material & finish (see page 102)*
 Sufijo p/peralte (ver pag 102) • *Rail height suffix (see page 102)*
 Ancho • *Width*
 Tipo marino • *Marine type*
 Tapa terminal • *Blind end*

No. de catálogo Catalog number	Ancho W Width W
PTRM-100	100
PTRM-200	200
PTRM-300	300
PTRM-400	400
PTRM-500	500
PTRM-600	600

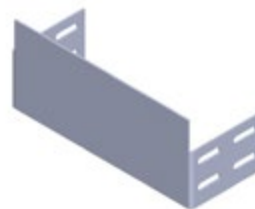

Incluye tornillería • *Hardware included*

Todas las dimensiones en mm (pulg) • *All dimensions are in mm (in)*

Sección 4.7

Soportería para cables tipo malla

Los sistemas de soportería para cables tipo malla fabricados por CROSS LINE son desarrollos pensados para instalaciones de control, señalización e iluminación, donde se requieren cargas bajas, como son: tiendas de autoservicio, cuartos de máquinas, cuartos de control, edificios inteligentes, cableados estructurados y toda aplicación donde no se presenten riesgos de daños a cables.

Los sistemas de soportería para cables tipo malla de CROSS LINE están fabricados de filamentos de acero longitudinales, de alta resistencia a la tensión, estos filamentos son unidos entre sí mediante filamentos transversales que le dan cohesión y rigidez al sistema.

El diseño exclusivo de CROSS LINE cuenta en la parte superior con filamentos continuos brindando flexibilidad ante cargas excesivas evitando el colapso del sistema.

Debido a la característica anterior existen señales visuales de que el sistema está sobrecargado y puede corregirse la carga, aun sin presentarse la falla del sistema.

Al evitarse el colapso, el sistema es más seguro que los sistemas rígidos.

El diseño del filamento superior evita la caída de los cables durante la instalación haciéndola más rápida y eficaz.

La posición del filamento superior evita el daño al aislamiento de los cables.

El diseño de la varilla continua, así como la geometría del mismo permiten que este funcione como rodillo haciendo más fácil el jalado de los cables durante la instalación.

Al ser ventilados los cables, permiten una mayor capacidad de conducción.

Permiten la acometida de cables tanto por la parte superior como inferior y lateral.

Son de fácil instalación y las modificaciones, así como derivaciones y curvas pueden realizarse en campo con herramientas mínimas.

El sistema es muchísimo más ligero que los sistemas rígidos ahorrando en anclaje, estructuración y sistemas de apoyo.

Por esta y muchas razones más:

Section 4.7

Wire mesh type cable tray system

CROSS LINE's wire mesh type cable tray system was designed thinking in control, signal and lighting electrical installation where light loads are required. Ideal for stores, control rooms, machines rooms, intelligent buildings, structural cabling and all applications where cables aren't in risk of damage.

CROSS LINE's wire mesh type cable tray system are made of high strength resistance steel, longitudinal filaments are joined for transversal wires providing cohesion and rigidity to the system.

CROSS LINE's wire mesh cable trays design have a filament in the top of the tray which gives high flexibility when the system is excessively loaded, preventing system's failure.

This filament makes possible to see when the system is overloaded. So this system is safer than rigid systems because it can't be overloaded. It also prevents insulation damage during installation.

This system makes installation and maintenance an easy and fast task.

The filament's position and form makes a roll bar function, enabling an easy installation while pulling cables

As this system is vented, it provides a wider conduction capacity. Moreover it makes possible to drop out cables from all positions, top, bottom and sides.

Installation and assembly needs are really easy to fulfill as fittings are field made with a minimum of tools.

This system is lighter than rigid systems offering to you a cheaper structural and support system.

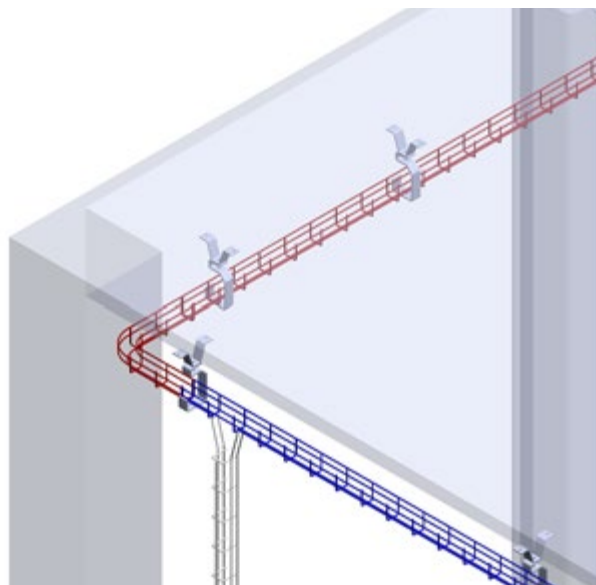

Tramo recto • Straight section

CL-10030GI

Material y acabado • *Material & finish*
 Sufijo p/peralte • *Rail height suffix*
 Ancho • *Width*
 Tramo recto • *Straight section*

N° de catálogo • *Catalog number*

Ancho W Width W	Peralte Height		
	30	55	105
50	CL-5030	CL-5055	
100	CL-10030	CL-10055	
150	CL-15030	CL-15055	
200	CL-20030	CL-20055	CL-200105
300	CL-30030	CL-30055	CL-300105
450		CL-45055	CL-450105
600			CL-600105

Longitud estandar 3.000 m • *Standard length 3.000 m*

Se puede solicitar con borde de seguridad engargolado. • *It can be ordered with seamed safety edge.*

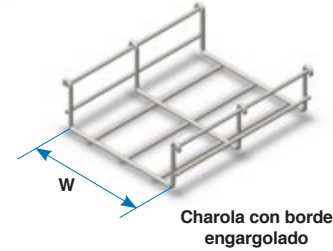
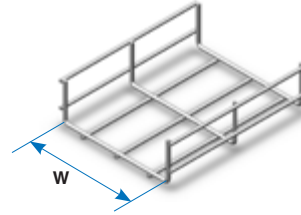
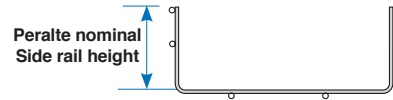

Mini-CL • Mini-CL

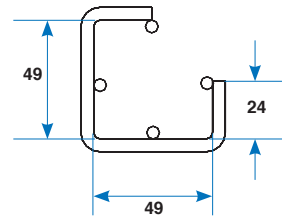

Los accesorios se fabrican a partir de tramos rectos en campo, por tanto no se ofrecen en este catálogo.

Conectores y tornillería no se incluyen, estos deberán ser solicitados por separado de acuerdo a los accesorios que serán fabricados en campo.

Fittings not showed should be field made using straight sections.

Neither connectors nor hardware are included, they should be requested according to the fitting you will make in field.

Materiales y acabados:

GI: Acero al carbón Galvanizado por Inmersión en caliente
GE: Acero al carbón Galvanizado Electrolítico
T: Acero al carbón Tropicalizado
PVC: Acero al carbón Recubierto con PVC según NEMA RN 1
AI: Acero inoxidable
P: Pintura electrostática (Ver gama de colores)
 Para materiales y acabados no indicados consulte nuestro departamento de ingeniería
 Todas las dimensiones en mm (pulg)

Materials & finishes:

GI: Hot dip galvanized steel
GE: Electro galvanized steel
T: Chromium-zinc coated steel
PVC: PVC coated steel under NEMA RN 1
AI: Stainless steel
P: Electrostatic paint (See color pattern)
 For materials and finishes not shown please consult our technical department
 All dimensions are in mm (in)

Conectores universales • Standard connectors

CUCL-01

Cada conector incluye • *Each connector includes*

No. de catálogo Catalog number	Pieza 1 Ditto 1	Pieza 2 Ditto 2
CUCL-01	CE-25	CE-30

Los conectores pueden ser solicitados por juego (CUCL) o por partes (CE)
Ambos conectores incluyen tornillería cuando son solicitados en juego
Al final del número de catálogo indicar material y acabado (ver página 108)

*Connectors can be requested in kit (CUCL) or in parts (CE)
Hardware included when they are requested in kit
At the end of the catalog number add material and finish (see page 108)*

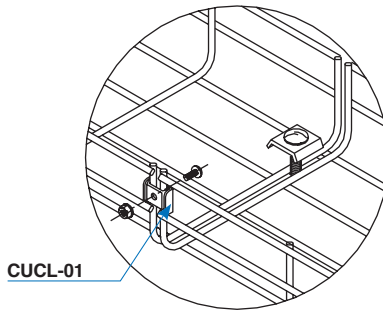

AEDT

Conector reforzado • Reinforced connector

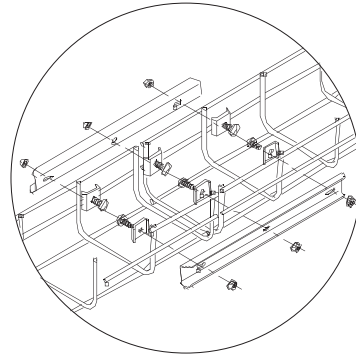

No incluye conectores ni tornillería • *Hardware and connectors are not included*
Al final del número de catálogo indicar material y acabado (ver página 108) • *At the end of the catalog number add material and finish (see page 108)*

AT 90

Conector angular • Angle connector

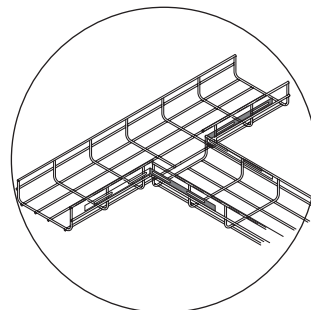

No incluye conectores ni tornillería • *Hardware and connectors are not included*
Al final del número de catálogo indicar material y acabado (ver página 108) • *At the end of the catalog number add material and finish (see page 108)*

Conectores rectos • Long splice plate

AD 275
AD 75

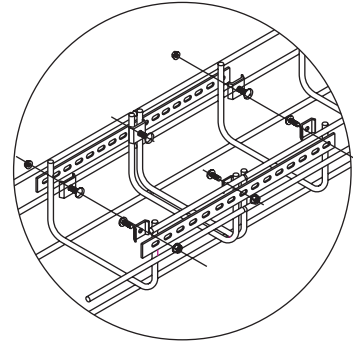

No incluye conectores ni tornillería • *Hardware and connectors are not included*
Al final del número de catálogo indicar material y acabado (ver página 108) • *At the end of the catalog number add material and finish (see page 108)*

Conectores angular corto • Small angular connector

AD 250/90

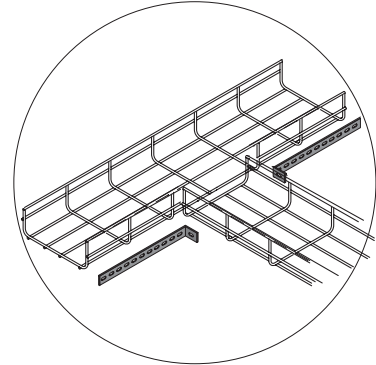

No incluye conectores ni tornillería • *Hardware and connectors are not included*
Al final del número de catálogo indicar material y acabado (ver página 108) • *At the end of the catalog number add material and finish (see page 108)*

Clip colgante • Hanger clamp

AS

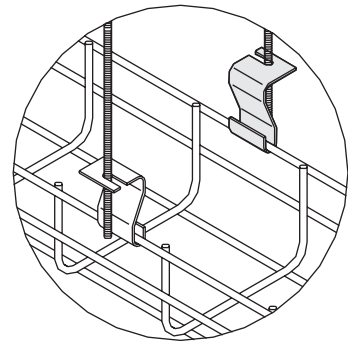

No incluye varilla • *Rod not included*
Al final del número de catálogo indicar material y acabado (ver página 108) • *At the end of the catalog number add material and finish (see page 108)*
Todas las dimensiones en mm (pulg) • *All dimensions are in mm (in)*

Soporte colgante • Hanger support

SCCL-100GI

Material y acabado (ver pag 108) • *Material & finish (see page 108)*
 Ancho • *Width*
 Colgador • *Hanger*

Ancho charola Tray width	No. de catálogo Catalog number
50	SCCL-50
100	SCCL-100
150	SCCL-150
200	SCCL-200
300	SCCL-300
450	SCCL-450
600	SCCL-600

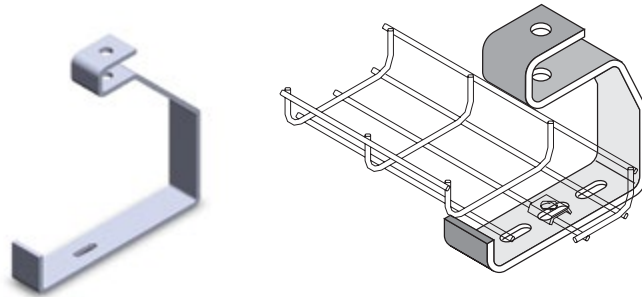

Ménsula para pared • Wall cantilever bracket

CRP-100GI

Material y acabado (ver pag 108) • *Material & finish (see page 108)*
 Ancho • *Width*
 Ménsula para charola de malla • *Wire mesh tray bracket*

Ancho charola Tray width	No. de catálogo Catalog number
50	CRP-50
100	CRP-100
150	CRP-150
200	CRP-200
300	CRP-300
450	CRP-450
600	CRP-600

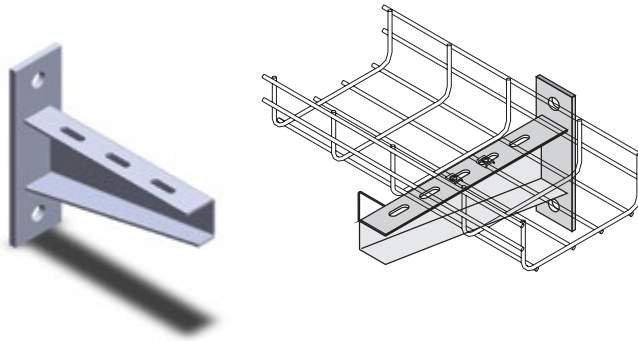

Canal horizontal para trapecio • Horizontal channel for trapeze support

CS-100GI

Material y acabado (ver pag 108) • *Material & finish (see page 108)*
 Ancho • *Width*
 Canal horizontal charola de malla • *Wire mesh tray horizontal channel*

Ancho charola Tray width	No. de catálogo Catalog number
50	CS-50
100	CS-100
150	CS-150
200	CS-200
300	CS-300
450	CS-450
600	CS-600

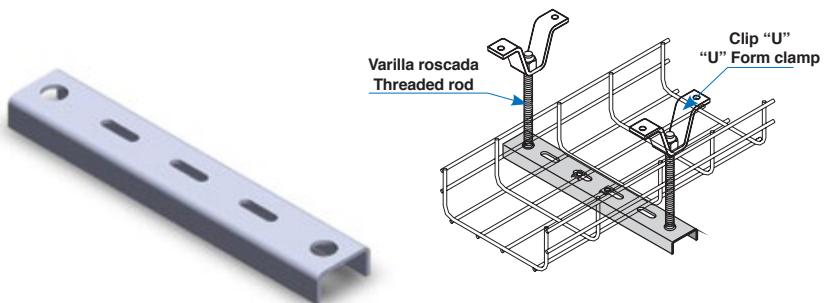

No incluye tornillería, varillas, clips "U" ni sistemas de fijación • *Hardware, "U" clamp, threaded rods or anchoring systems are not included.*
 Todas las dimensiones en mm (pulg) • *All dimensions are in mm (in)*

Canal universal • Universal channel

UCSN-500GI

Material y acabado (ver pag 108) • Material & finish (see page 108)
 Longitud • Length
 Canal universal • Universal channel

Longitud del canal Channel length	No. de catálogo Catalog number
150	UCSN-150
200	UCSN-200
300	UCSN-300
400	UCSN-400
500	UCSN-500
600	UCSN-600
1000	UCSN-1000
2000	UCSN-2000
3000	UCSN-3000

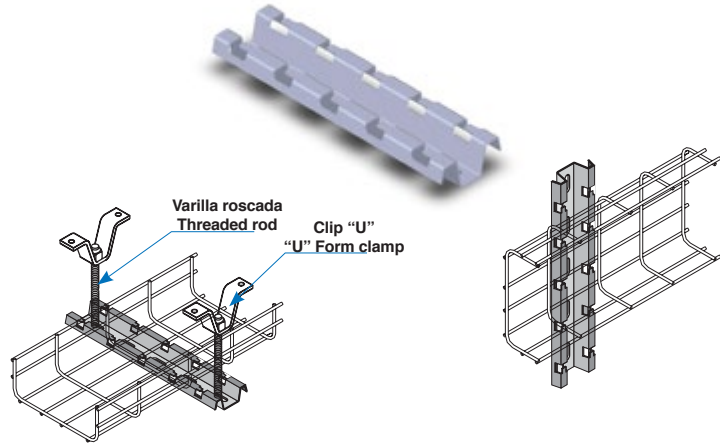

No incluye tornillería, varillas, clips "U" ni sistemas de fijación • Hardware, "u" clamp, threaded rods or anchoring systems are not included

Ménsula de ensamble rápido • Fast assembly bracket

MSNC

No. de catálogo Catalog number	Longitud L Length L
MSNC-100	178
MSNC-150	228
MSNC-200	278
MSNC-300	378
MSNC-450	528
MSNC-600	678

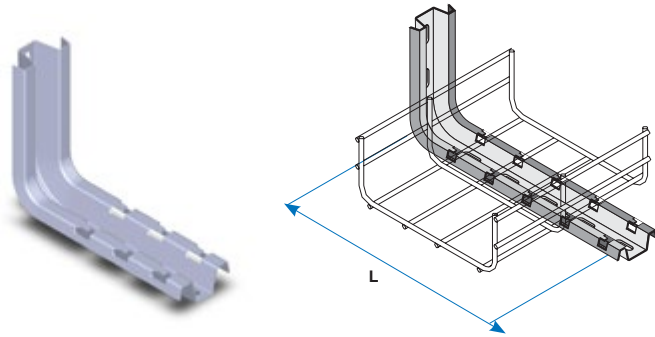

Al final del número de catálogo indicar material y acabado (ver página 108) • At the end of the catalog number add material and finish (see page 108)

Soporte para piso • Floor support

SPCL

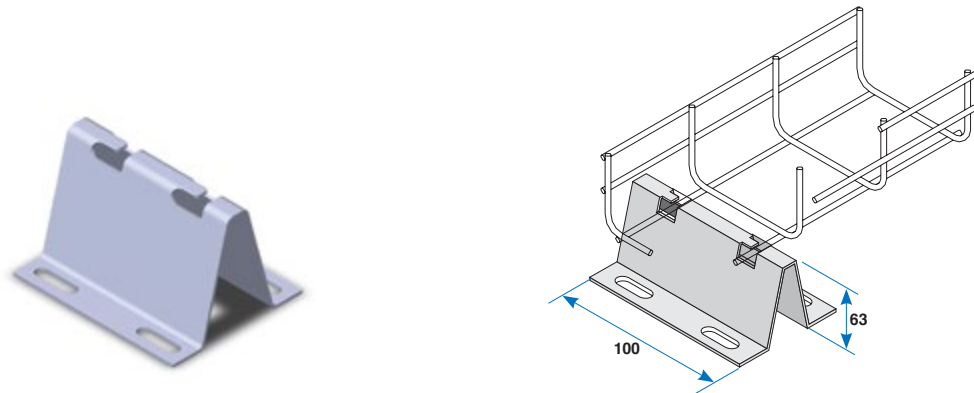

Al final del número de catálogo indicar material y acabado (ver página 108) • At the end of the catalog number add material and finish (see page 108)
 Todas las dimensiones en mm (pulg) • All dimensions are in mm (in)

Soporte a muro o caja • Wall or box support

CM-55
CM-55XL

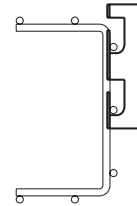
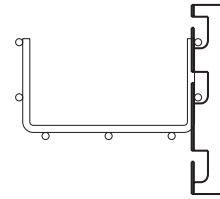

Al final del número de catálogo indicar material y acabado (ver página 108) • At the end of the catalog number add material and finish (see page 108)

Tapas • Covers

TCCL-100GI

Material y acabado (ver pag 108) • Material & finish (see page 108)

Ancho • Width

Tapa con ceja para charola tipo malla • Flanged cover for wire mesh tray

No. de catálogo Catalog number	Ancho charola Tray width
TCCL-50	50
TCCL-100	100
TCCL-150	150
TCCL-200	200
TCCL-300	300
TCCL-450	450
TCCL-600	600

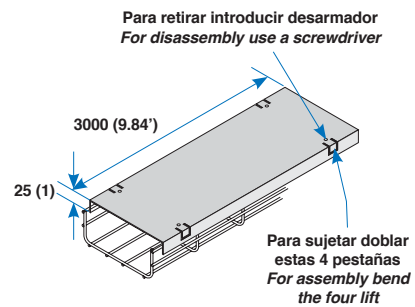
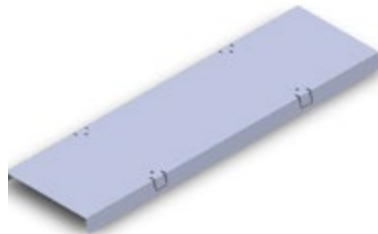

Debido a que en charola tipo malla las derivaciones se realizan a partir de tramos rectos, las tapas para derivaciones deberán obtenerse a partir de tapas rectas.

Fitting covers should be field made using straight section covers.

Bajada para cable • Drop out

BCL-10R50

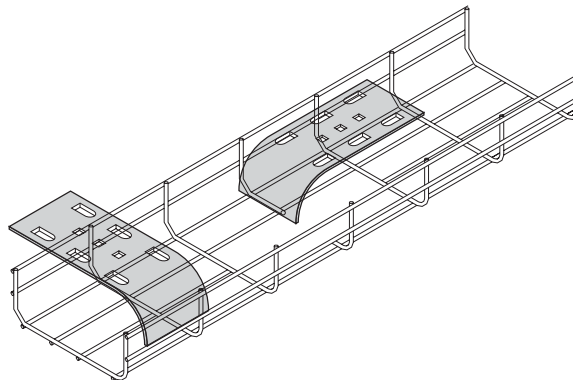

Al final del número de catálogo indicar material y acabado (ver página 108) • At the end of the catalog number add material and finish (see page 108)
Todas las dimensiones en mm (pulg) • All dimensions are in mm (in)

Sección 5 Canaletas

Section 5 Cable channel

- | | |
|--|---|
| <ol style="list-style-type: none"> 1. Tramo recto de canal perforado • <i>Slotted channel straight section</i> 1A. Tramo recto de canal sólido • <i>Solid trough type channel</i> 2. Conector "U" para canal. • <i>"U" splice plate</i> 3. Conector reductor para canal • <i>Reducer splice plate</i> 4. Conector "T" para canal • <i>"T" splice plate</i> 5. Conector "X" para canal • <i>"X" splice plate</i> 6. Conector de canal a caja • <i>Frame type box connector</i> | <ol style="list-style-type: none"> 7. Conector vertical ajustable • <i>Vertical adjustable splice plate</i> 8. Conector horizontal ajustable • <i>Horizontal adjustable splice plate</i> 9. Soporte colgante para canal • <i>Channel hanger</i> 10. Soporte doble para canal • <i>Double channel support</i> 11. Ménsula de pared • <i>Wall cantilever bracket</i> 12. Placa cierre para canal • <i>Channel blind end</i> |
|--|---|

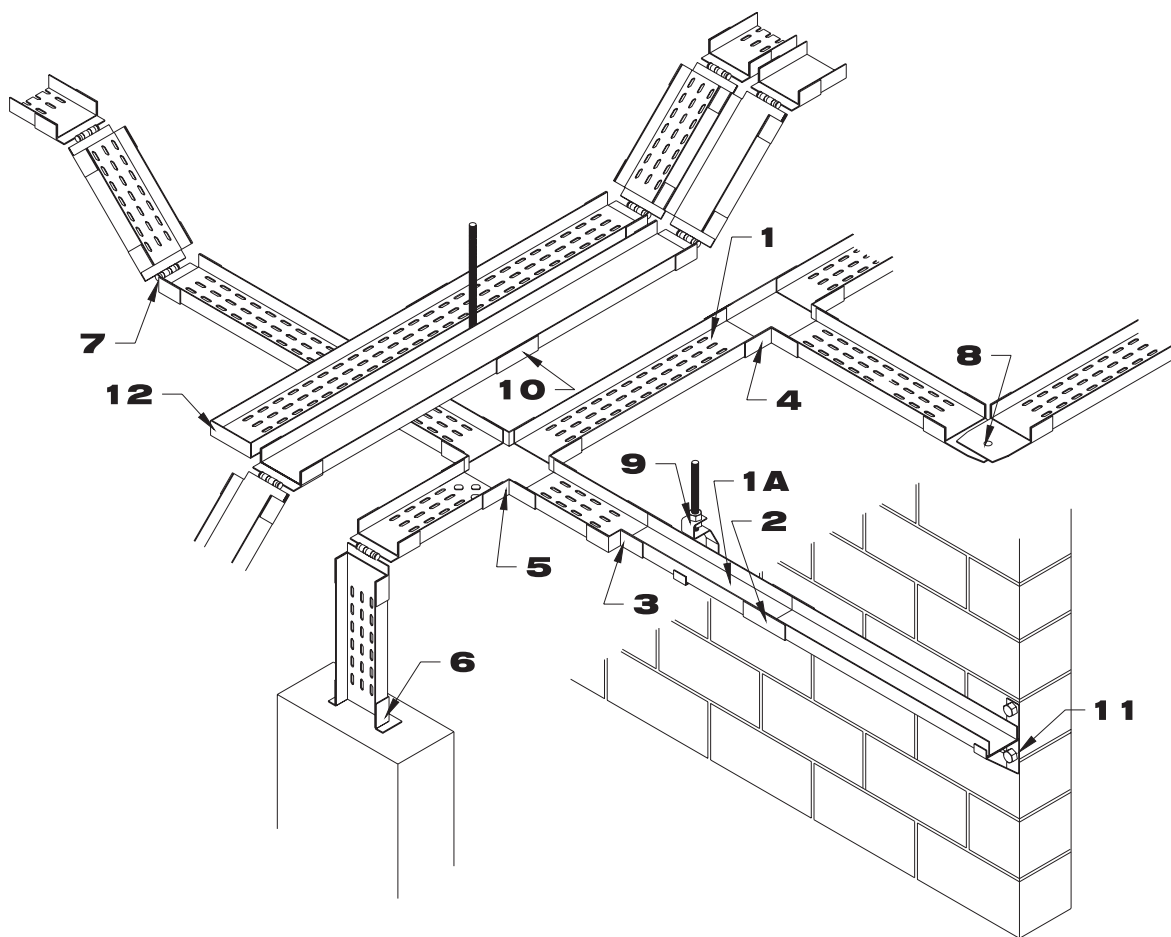

Tramo recto • Straight section

CHSV-4152 32A

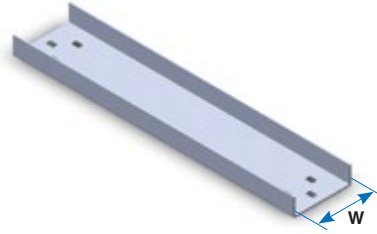
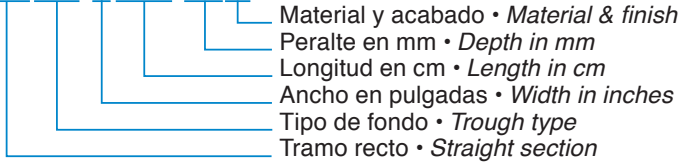

Nº de catálogo • *Catalog number*

Ancho W Width W	Fondo perforado <i>Slotted Trough</i>		Fondo liso <i>Solid Trough</i>	
	Longitud • <i>Length</i>		Longitud • <i>Length</i>	
	1524 (60)	3048 (120)	1524 (60)	3048 (120)
76 (3)	CHCV-3152	CHCV-3305	CHSV-3152	CHSV-3305
102 (4)	CHCV-4152	CHCV-4305	CHSV-4152	CHSV-4305
152 (6)	CHCV-6152	CHCV-6305	CHSV-6152	CHSV-6305

Ancho W Width W	Peralte Depth
76 (3)	32 mm (1 1/4")
102 (4)	32 mm (1 1/4")
	44 mm (1 3/4")
152 (6)	44 mm (1 3/4")

Incluye conector y tornillería • *Connector and hardware included*

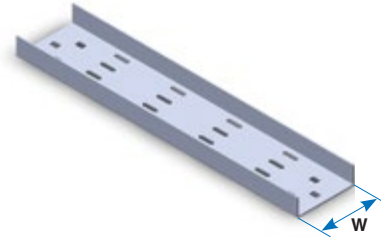

Conector "U" • "U" Splice plate

AUCV-3 A

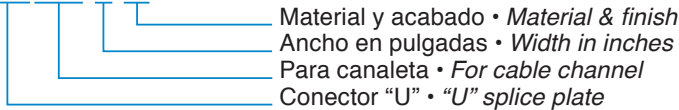

No. de catálogo <i>Catalog number</i>	Ancho W Width W
AUCV-3	76 (3)
AUCV-4	102 (4)
AUCV-6	152 (6)

Incluye tornillería • *Hardware included*

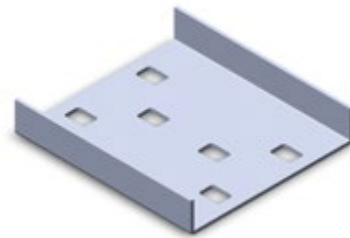

Materiales y acabados:

A: Aluminio aleación AA-3003 acabado natural
GI: Acero al carbón galvanizado por inmersión en caliente
GE: Acero al carbón galvanizado electrolítico
T: Acero al carbón tropicalizado
PVC: Acero al carbón recubierto con PVC según NEMA RN 1
PVA: Aluminio recubierto con PVC según NEMA RN 1
AI: Acero inoxidable
 Para materiales y acabados no indicados consulte nuestro departamento de ingeniería.
 Todas las dimensiones en mm (pulg).

Materials & finishes:

A: AA-3003 natural finished aluminum
GI: Hot dip galvanized steel
GE: Electro galvanized steel
T: Chromium-zinc coated steel
PVC: PVC coated steel under NEMA RN 1
PVA: PVC coated aluminum under NEMA RN 1
AI: Stainless steel
 For materials and finishes not shown please consult our technical department.
 All dimensions are in mm (in).

Conector "T" • "T" Splice plate

ATCV-3 A

- Material y acabado (ver pág. 115) • *Material & finish (see page 115)*
- Ancho en pulgadas • *Width in inches*
- Para canaleta • *For cable channel*
- Conector "T" • *"T" splice plate*

No. de catálogo <i>Catalog number</i>	Ancho W <i>Width W</i>
ATCV-3	76 (3)
ATCV-4	102 (4)
ATCV-6	152 (6)

Incluye tornillería • *Hardware included*

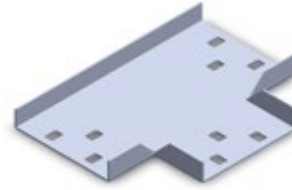

Conector "X" • "X" Splice plate

AXCV-3 A

- Material y acabado (ver pág. 115) • *Material & finish (see page 115)*
- Ancho en pulgadas • *Width in inches*
- Para canaleta • *For cable channel*
- Conector "X" • *"X" splice plate*

No. de catálogo <i>Catalog number</i>	Ancho W <i>Width W</i>
AXCV-3	76 (3)
AXCV-4	102 (4)
AXCV-6	152 (6)

Incluye tornillería • *Hardware included*



Conector reductor • Reducer splice plate

ARCV-63 A

- Material y acabado (ver pág. 115) • *Material & finish (see page 115)*
- Ancho menor en pulg. • *Smallest width in inches*
- Ancho mayor en pulg. • *Largest width in inches*
- Para canaleta • *For cable channel*
- Conector reductor • *Reducer splice plate*

N° de catálogo • *Catalog number*

Ancho W1 <i>Width W1</i>	Ancho W2 <i>Width W2</i>	
	76 (3)	102 (4)
102 (4)	ARCV-43	
152 (6)	ARCV-63	ARCV-64

Incluye tornillería • *Hardware included*

Todas las dimensiones en mm (pulg) • *All dimensions are in mm (in)*

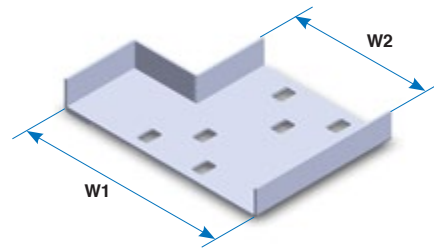

Conector vertical ajustable • Vertical adjustable splice plate

AVACV-3 A

- Material y acabado (ver pág. 115) • *Material & finish (see page 115)*
- Ancho en pulgadas • *Width in inches*
- Para canaleta • *For cable channel*
- Conector vertical ajustable • *Vertical adjustable splice plate*

No. de catálogo <i>Catalog number</i>	Ancho W <i>Width W</i>
AVACV-3	76 (3)
AVACV-4	102 (4)
AVACV-6	152 (6)

Incluye tornillería • *Hardware included*



Conector horizontal ajustable • Horizontal adjustable splice plate

AHACV-3 A

- Material y acabado (ver pág. 115) • *Material & finish (see page 115)*
- Ancho en pulgadas • *Width in inches*
- Para canaleta • *For cable channel*
- Conector horizontal ajustable • *Horizontal adjustable splice plate*

No. de catálogo <i>Catalog number</i>	Ancho W <i>Width W</i>
AHACV-3	76 (3)
AHACV-4	102 (4)
AHACV-6	152 (6)

Incluye tornillería • *Hardware included*



Conector a caja • Frame box connector

ACCV-6 A

- Material y acabado (ver pág. 115) • *Material & finish (see page 115)*
- Ancho de canaleta • *Channel width*
- Conector a caja para canaleta • *Channel frame box connector*

Nº de catálogo • Catalog number

Ancho W1 <i>Width W1</i>	Ancho W2 <i>Width W2</i>
ACCV-3	76 (3)
ACCV-4	102 (4)
ACCV-6	152 (6)

Incluye tornillería • *Hardware included*

Todas las dimensiones en mm (pulg) • *All dimensions are in mm (in)*

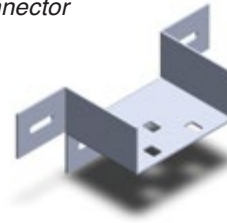

Placa terminal • Blind end

PTRCV-3 A

- Material y acabado (ver pág. 115) • *Material & finish (see page 115)*
- Ancho en pulgadas • *Width in inches*
- Para canaleta • *For cable channel*
- Placa terminal • *Blind end*

No. de catálogo <i>Catalog number</i>	Ancho W <i>Width W</i>
PTRCV-3	76 (3)
PTRCV-4	102 (4)
PTRCV-6	152 (6)

Incluye tornillería • *Hardware included*



Tapas • Covers

TCHCV-3152 A

- Material y acabado (ver pág. 115) • *Material & finish (see page 115)*
- Longitud en cm • *Length in cm*
- Ancho en pulgadas • *Width in inches*
- Tipo de fondo • *Trough type*
- Tapa para tramo recto • *Cover for straight section*

Nº de catálogo • Catalog number

Ancho W <i>Width W</i>	Longitud <i>Length</i>	
	1524 (60)	3048 (120)
76 (3)	TCHCV-3152	TCHCV-3305
102 (4)	TCHCV-4152	TCHCV-4305
152 (6)	TCHCV-6152	TCHCV-6305

Todas las dimensiones en mm (pulg) • *All dimensions are in mm (in)*



Clip de sujeción para tapa • Cover clamp

CSTCV-14GI

Material y acabado (ver pág. 115) • *Material & finish (see page 115)*
 Clip de sujeción para tapa • *Cover clamp*

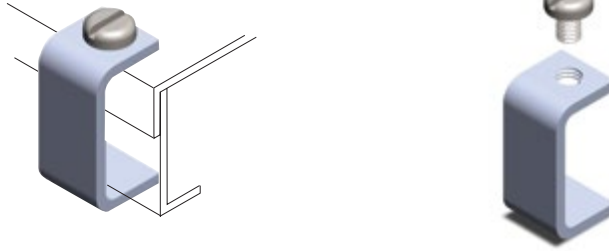

Incluye tornillería • *Hardware included*

Ménsula para pared • Wall cantilever bracket

MPCV-3GI

Material y acabado (ver pág. 115 excepto aluminio) • *Material & finish (see page 115 except aluminum)*
 Ancho en pulgadas • *Width in inches*
 Para canaleta • *For cable channel*
 Ménsula para pared • *Wall cantilever bracket*

No. de catálogo <i>Catalog number</i>	Ancho W <i>Width W</i>
MPCV-3	76 (3)
MPCV-4	102 (4)
MPCV-6	152 (6)

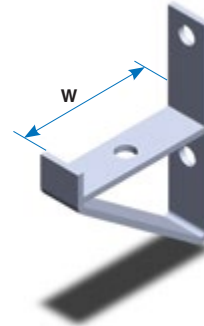

Soporte doble • Double hanger support

SDCV-3GI

Material y acabado (ver pág. 115 excepto aluminio) • *Material & finish (see page 115 except aluminum)*
 Ancho en pulgadas • *Width in inches*
 Para canaleta • *For cable channel*
 Soporte doble • *Double support*

No. de catálogo <i>Catalog number</i>	Ancho W <i>Width W</i>
SDCV-3	76 (3)
SDCV-4	102 (4)
SDCV-6	152 (6)

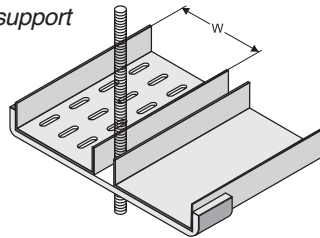

Soporte colgante • Hanger support

SCCV-3GI

Material y acabado (ver pág. 113 excepto aluminio) • *Material & finish (see page 113 except aluminum)*
 Ancho en pulgadas • *Width in inches*
 Para canaleta • *For cable channel*
 Soporte colgante • *Hanger support*

No. de catálogo <i>Catalog number</i>	Ancho W <i>Width W</i>
SCCV-3	76 (3)
SCCV-4	102 (4)
SCCV-6	152 (6)

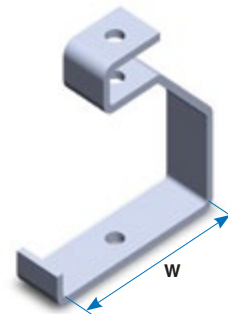

Todas las dimensiones en mm (pulg) • *All dimensions are in mm (in)*